

NEW

Durant Tool Company

**Coil Handling Equipment
Wire Machinery
Rotary Turntables
Durant Counters**

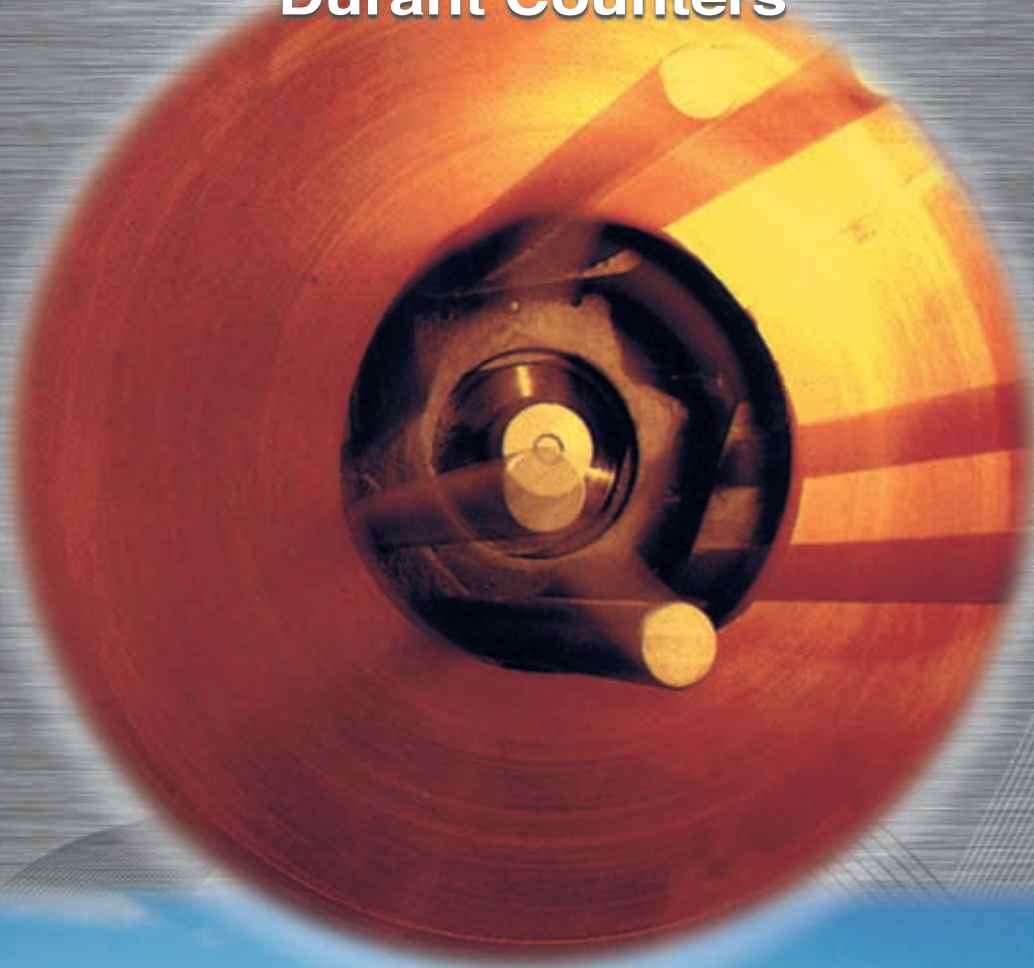

www.durantco.com

2016

Durant Tool Company

Counters, Wire Machinery, Coil Handling Equipment
and Rotary Turntables

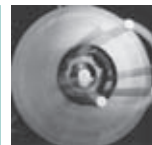

Good Morning!

Here is your special copy of the completely new, full color DURANT Tool Catalog, packed with 68 pages of the latest products and accessories for the Coil Handling and Wire Industry, including Rotary Turntables, Stretch Wrap Turntables, and Durant Counters.

Everything is at outstanding prices. For over 75 years Durant manufacturing, engineering and development have helped our customers worldwide, find superior items offering the finest quality and best dollar value.

Whatever you need or want, you will find it here. Check the handy contents column on the next page to help you find the right section.

See for yourself. Look through the catalog now and compare. I think you will agree that these are excellent products at prices among the lowest in the industry. I promise you that they will perform, trouble-free, over, and over for years and years.

**Durant products are warrantied for three full years against all material or workmanship failure. (See our warranty on page 67 for details.)
We will replace it or repair it.**

So pick out the items you need, and telephone, fax, or mail in your order. We will do the rest. For even faster service, call TOLL FREE 1-800-D-DURANT between 8:00am and 4:30pm EST/DST. Or Fax 1-401-738-2586, 24 hours a day.

Either way our friendly, knowledgeable, customer service representatives are standing by, waiting to process your order—quickly, accurately and completely.

How can you lose? Quality products! Competitive pricing! Reliable delivery! And every Durant item warrantied! If you are a longtime Durant customer, you know that is true. If you have not done business with us before, try us now and you will find out that it really is.

I look forward to receiving your order, and I thank you in advance.

Sincerely,

Edward W. Bouclin
President

200 Circuit Drive • North Kingstown, Rhode Island 02852 • USA
International Phone: 1-401-781-7800 • Toll Free: 800-338-7268 • Fax: 1-401-738-2586
• Internet Address: <http://www.durantco.com> •

INTERNATIONAL GLOBAL NETWORK

Durant has thousands of industrial manufacturing partners throughout North America, South America, Europe, Middle East and Asia. Use our toll free number.

1-800-D-DURANT OR 1-800-338-7268

DURANT TOOL COMPANY

200 CIRCUIT DRIVE
NORTH KINGSTOWN,
RHODE ISLAND 02852 USA

Tele: (401) 781-7800
Fax: (401) 738-2586

INTERNET ADDRESS:
www.durantco.com



All components manufactured by Durant Tool Company are warrantied for three years against defects in material or workmanship, given normal and intended use. Durant will repair or replace all equipment at its discretion.

(See page 67 for details.)

CONTENTS	PAGES
<i>Coil Handling, Material Feeding & Cutting Machinery</i>	
Flat Stock Servo Roll Feeders	4-8
Servo Roll Feeder Options	9
Flat Material Cut to Length Machines	10-11
Roll Feeder/Flat Stock Straighteners	12
Air Feeders	13-15
Material Lubricators	16-17
Pallet Type Uncoilers /Decoilers	18-23
Unwind/Rewind Uncoilers Recoilers	24-35
Flat Stock Coil Straighteners Non-Motorized	36
Flat Stock Coil Straighteners Motorized	37-41
Material Loop Controllers	42
Pneumatic Parts/Pieces Transporters	43
Motorized Scrap Cutters	44-45
<i>Wire Machinery</i>	
Wire Uncoilers	46-48
Wire Spool Uncoilers	49
Wire Straighteners	50-51
Round/Square Wire Roll Feeders	52
Flat Material/Wire Measuring Machines.....	53
Wire Cut to Length Machines	54-55
<i>Rotary Turntables Exhibit Display, Factory Automation Packaging, Stretch Wrapping</i>	
Rotary Turntables Non-Motorized & Motorized	56-59
Stretch Wrapping Turntables	60
Pedestal Turntables & Cabinet Turntables	61
<i>Durant Counters & Controllers</i>	62-66

Flat Stock Servo Roll Feeders

Low maintenance high performance machines...



**HP-6
Servo Roll Feed**

When making an investment in Electronic Servo Feeds, Electronic Servo Feeds with Pull Thru Straighteners or Electronic Servo Feeds with Stock Cutters for Cut-To-Length applications, Durant is the solution for your requirements. Durant is a team building the Electronic Servo Feed suited particularly for your application. Durant can provide you with our standard feed body and electronics package or make necessary modifications at a very reasonable cost. Durant manufactures Servo Roll Feeds that provide power, speed, and precision feed accuracy for all applications.

Durant Tool Company offers thirty models. All feed body parts are manufactured from precision CNC machine technology and have a black oxide machine tool finish. These low maintenance high performance machines incorporate the latest Servo technology.

The electronic control package consists of an operator interface keypad with the industries most user friendly roll feed software on the market today. The keypad contains various system performance data and accumulators.

See
Pages 10-11

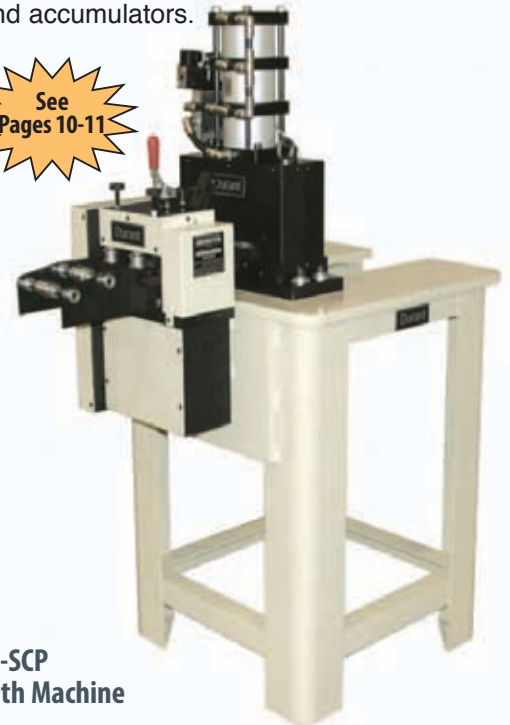

**MP-6-SCP
Cut-To-Length Machine**

SELECTION

Durant manufactures thirty standard models of high quality competitively priced Electronic Servo Feeds. Machines handle applications to .250" thick mild steel and 60" wide material. When feeding plastic, foam, fiber or materials other than steel, material thickness is considerably greater than stated maximum material thickness. Please contact Durant.

VERSATILITY

Durant Servo Feeds are built to handle materials thick or thin, narrow or wide, flimsy or rigid, in metal, plastic, foam, or paper. If our standard specifications do not meet your requirements, call Durant.

ACCURACY

Durant's high quality CNC machined feed body exceeds the manufacturing specifications of all other Servo Feed manufacturers. Cluster gears on top & bottom rolls for zero backlash regardless of material thickness

Durant's Electronic controls are combined with the most accurate feed body, to give you, our customer, the premier Electronic Servo Feed.



Flat Stock Servo Roll Feeders

INSTALLATION

Installation is a snap with Durant. The MP and VP Series includes an adjustable mounting bracket as standard. Only four bolts are necessary for quick easy installation. The FP and HP Series allows for the heavy duty adjustable mounting bracket as an optional item. We recommend this item to make your installation and operation a smooth, trouble-free experience.

CONSTRUCTION

Every model is engineered and machined from the latest CNC Technology and black oxide finished to give our customers the premier Electronic Servo Feed.

COMPARISON

Put our Electronic Servo Feeds beside any other comparative unit you have heard about. We won't need to say anything more. You win with Durant! We win with you!

STANDARD MECHANICAL FEATURES

- Precision Machined construction.
- Black Oxide finished.
- Mechanical Pilot Release.
- Matte finished rolls.
- Zero maintenance sealed bearings.

- Cluster gears on top & bottom rolls for zero backlash regardless of material thickness.
- Zero maintenance low inertia pulley mounted with trantorque keyless bushing.
- Zero maintenance Kevlar belt which eliminates lubrication & wear.
- Brushless servo motor.
- Adjustable roller stock guides.
- Positive pressure die springs on upper roll.
- Cascade entry rolls.
- Color: Ivory or customer to specify.

STANDARD ELECTRIC CONTROL FEATURES

- Control enclosure is a rugged 24x20x12 free standing NEMA 12 cabinet. MP cabinet is 20x16x8" deep.
- Operator control: Power On/Off selector switch, Emergency Stop push-pull button, Index push button, Auto/Manual/Jog to Length selector switch & remote forward / reverse jog station.
- Operator interface keypad and display.
- Electronic Control is wired to JIC and NEC standards.

42" WIDE MATERIAL BY .040" THICK MILD STEEL.

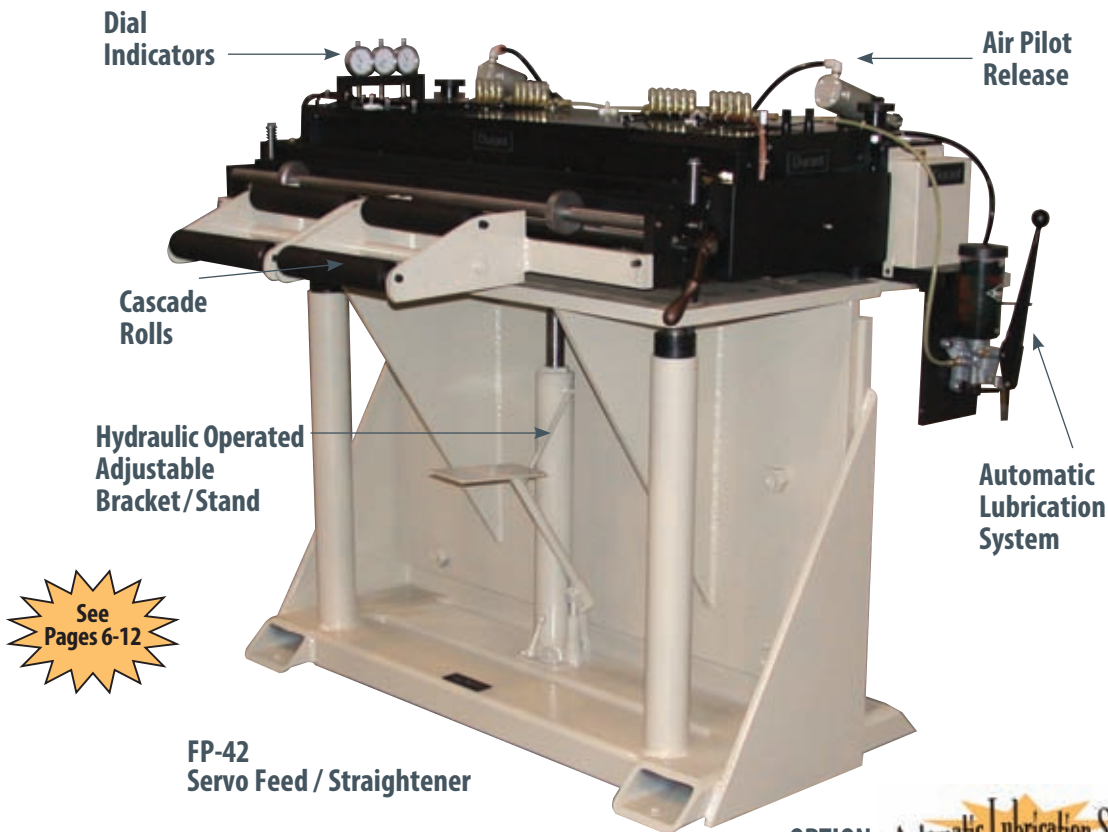

FP-42
Servo Feed / Straightener

OPTION: Automatic Lubrication System

MP-VP Series Servo Roll Feeders

Durant's MP-VP Series Servo Roll Feeds are heavy duty, rugged machines for high speed, demanding applications up to .125" thick steel feeding requirements.

Feed body frames are manufactured with solid steel CNC technology. NO inexpensive castings that will fatigue and crack. All frames are dowel-pinned and screwed with precision components.

The #1 rated feed body, manufactured by Durant to the most rigid standards with The Allen Bradley Electronics Package, gives you, our customer, a trouble-free production investment.

From
\$6970⁰⁰
 MP-3



MP-VP-3

STANDARD MECHANICAL FEATURES

- Precision Machined construction, solid steel.
- Black Oxide finished.
- Mechanical Pilot Release.
- Matte finished rolls.
- Zero maintenance sealed bearings.
- Cluster gears on top & bottom rolls for zero backlash regardless of material thickness.
- Zero maintenance low inertia pulley mounted with trantorque keyless bushing.
- Zero maintenance Kevlar belt which eliminates lubrication & wear.
- Brushless servo motor.
- Adjustable roller stock guides.
- Positive pressure die springs on upper roll.
- Casade entry rolls.
- Color: Ivory or customer to specify.

MP-VP SERIES SERVO ROLL FEED						
Model	Max. Material Width	Max. Thickness	Max. Feed Length	Roll Diameter	Input Voltage	Motor & AMP
MP-3	3"	.062	999.99	2.00	230/1/60	10 AMP RATING
MP-6	6"	.062	999.99	2.00	230/1/60	
MP-12	12"	.062	999.99	2.00	230/1/60	
MP-18	18"	.062	999.99	2.00	230/1/60	
MP-24	24"	.062	999.99	2.00	230/1/60	
VP-3	3"	.125	999.99	2.00	230/1/60	20 AMP RATING
VP-6	6"	.125	999.99	2.00	230/1/60	
VP-12	12"	.125	999.99	2.00	230/1/60	
VP-18	18"	.090	999.99	2.00	230/1/60	
VP-24	24"	.090	999.99	2.00	230/1/60	
VP-30	30"	.090	999.99	2.00	230/1/60	
VP-36	36"	.090	999.99	2.00	230/1/60	

STANDARD ELECTRIC CONTROL FEATURES

- Control enclosure is a rugged free standing NEMA 12 cabinet 20x16x8" deep.
- Operator control: Power On/Off selector switch, Emergency Stop push-pull button, Index push button, Auto/Manual/Jog to Length selector switch & remote forward / reverse jog station.
- Operator interface keypad and display.
- Electronic Control is wired to JIC and NEC standards.



FP Series Servo Roll Feeders

Durant's FP Series Servo Roll Feeds are heavy duty, rugged machines for high speed, demanding applications up to .210" thick steel feeding requirements.

Feed body frames are manufactured with solid steel CNC technology. NO inexpensive castings that will fatigue and crack. All frames are dowel-pinned and screwed with precision components.

The #1 rated feed body, manufactured by Durant to the most rigid standards with The Allen Bradley Electronics Package, gives you, our customer, a trouble-free production investment.

STANDARD MECHANICAL FEATURES

- Precision Machined construction, solid steel.
- Black Oxide finished.
- Mechanical Pilot Release.
- Matte finished rolls.
- Zero maintenance sealed bearings.
- Cluster gears on top & bottom rolls for zero backlash regardless of material thickness.
- Zero maintenance low inertia pulley mounted with trantorque keyless bushing.
- Zero maintenance Kevlar belt which eliminates lubrication & wear.
- Brushless servo motor.
- Adjustable roller stock guides.
- Positive pressure die springs on upper roll.
- Casade entry rolls.
- Color: Ivory or customer to specify.

STANDARD ELECTRIC CONTROL FEATURES

- Control enclosure is a rugged 24x20x12 free standing NEMA 12 cabinet.
- Operator control: Power On/Off selector switch, Emergency Stop push-pull button, Index push button, Auto/Manual/Jog to Length selector switch & remote forward/reverse jog station.
- Operator interface keypad and display.
- Electronic Control is wired to JIC and NEC standards.

OPTIONS:

- Air pilot release with Open / Close / Automatic selector switch on Electronic control
- Adjustable Mounting Bracket (up to 4 inch adjustment)
- Air operated roll hold down tension
- Urethane Rolls
- Knurled Rolls
- Straighteners

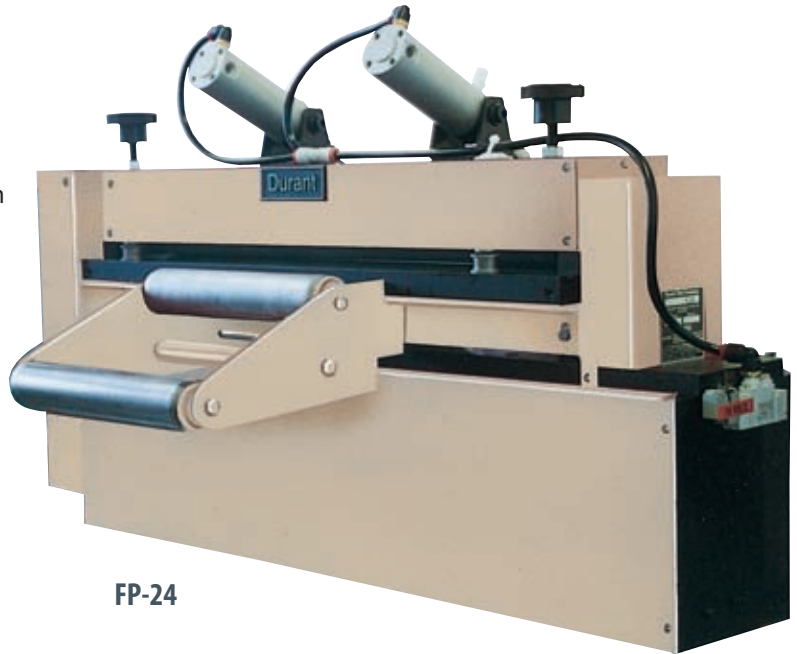

FP-24

FP SERIES SERVO ROLL FEED						
Model	Max. Material Width	Max. Thickness	Max. Feed Length	Roll Diameter	Input Voltage	Motor & AMP
FP-3	3"	.210	999.99	2.75	230/1/60	30 AMP RATING
FP-6	6"	.181	999.99	2.75	230/1/60	
FP-12	12"	.156	999.99	2.75	230/1/60	
FP-18	18"	.125	999.99	2.75	230/1/60	
FP-24	24"	.125	999.99	2.75	230/1/60	
FP-30	30"	.090	999.99	2.75	230/1/60	
FP-36	36"	.090	999.99	2.75	230/1/60	

Automatic Lubrication System

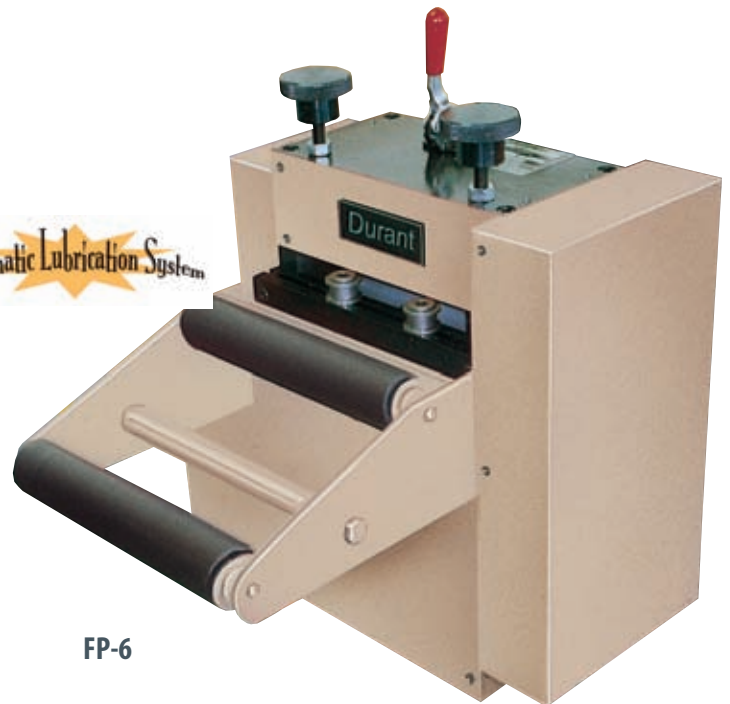

FP-6

FP-HP
Control Cabinet

HP Series Servo Roll Feeders

Heavy Duty HP Series Servo Roll feed Delivers: POWER! SPEED! PERFORMANCE! PRECISION FEEDING ACCURACY!



HP-6

Durant's HP Series Servo Roll Feeds are heavy duty, rugged machines for high speed, demanding applications up to .250" thick steel feeding requirements.

Feed body frames are manufactured with solid steel CNC technology. NO inexpensive castings that will fatigue and crack. All frames are dowel-pinned and screwed with precision components.

The #1 rated feed body, manufactured by Durant to the most rigid standards with The Allen Bradley Electronics Package, gives you, our customer, a trouble-free production investment.

STANDARD MECHANICAL FEATURES

- Precision Machined construction, solid steel.
- Black Oxide finished.
- Mechanical Pilot Release.
- Matte finished rolls.
- Zero maintenance sealed bearings.
- Cluster gears on top & bottom rolls for zero backlash regardless of material thickness.
- Zero maintenance low inertia pulley mounted with trantorque keyless bushing.
- Zero maintenance Kevlar belt which eliminates lubrication & wear.
- Brushless servo motor.
- Adjustable roller stock guides.
- Positive pressure die springs on upper roll.
- Cascade entry rolls.
- Color: Ivory or customer to specify.

STANDARD ELECTRIC CONTROL FEATURES

- Control enclosure is a rugged 24x20x12 free standing NEMA 12 cabinet.
- Operator control: Power On/Off selector switch, Emergency Stop push-pull button, Index push button, Auto/Manual/Jog to Length selector switch & remote forward / reverse jog station.
- Operator interface keypad and display.
- Electronic Control is wired to JIC and NEC standards.

HP SERIES SERVO ROLL FEED

Model	Max. Material Width	Max. Thickness	Max. Feed Length	Roll Diameter	Input Voltage	Motor & AMP
HP-6	6"	.250	999.99	3.50	220/1/60	30-75 AMP RATING
HP-12	12"	.210	999.99	3.50	220/1/60	
HP-18	18"	.187	999.99	3.50	220/1/60	
HP-24	24"	.156	999.99	3.50	220/1/60	
HP-30	30"	.125	999.99	3.50	220/1/60	
HP-36	36"	.090	999.99	3.50	220/1/60	
HP-48	48"	.065	999.99	3.50	220/3/60	
HP-60	60"	.040	999.99	3.50	220/3/60	

Servo Roll Feeders Options

Double Servo Roll Feeds (Push / Pull)

When feeding thin, delicate material, the Double Servo Roll Feed is the best machine recommendation. Two synchronized feed bodies, simultaneously pushing and pulling the material, eliminates buckling associated with gaskets, foils, and other delicate materials. One control station services the dual tandem feed bodies. All Durant Servo Roll Feeds are available in double models. Call Durant with your requirements!

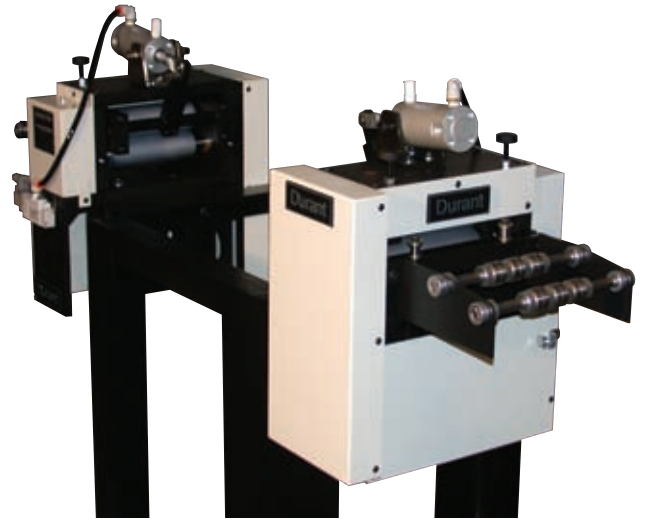

Pneumatic Pilot Release



Heavy Duty Adjustable Mounting Bracket

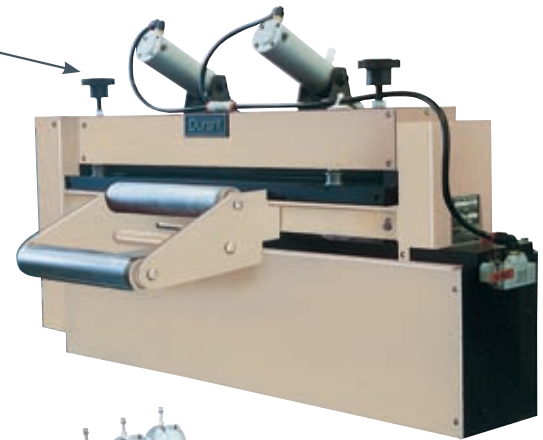
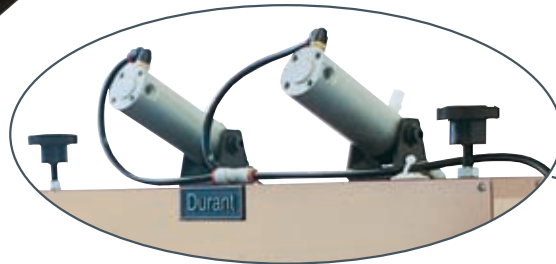

Pull Thru Straighteners . . .

See
Pages 36, 50, 51

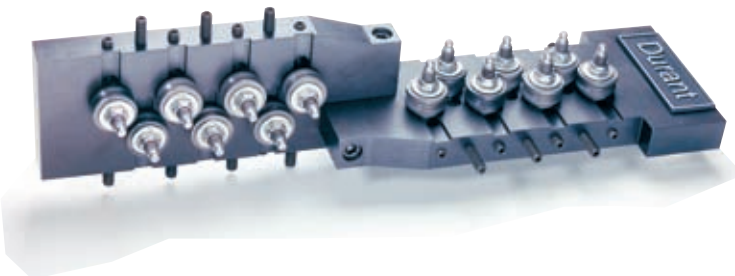

WS-7 Wire Straightener

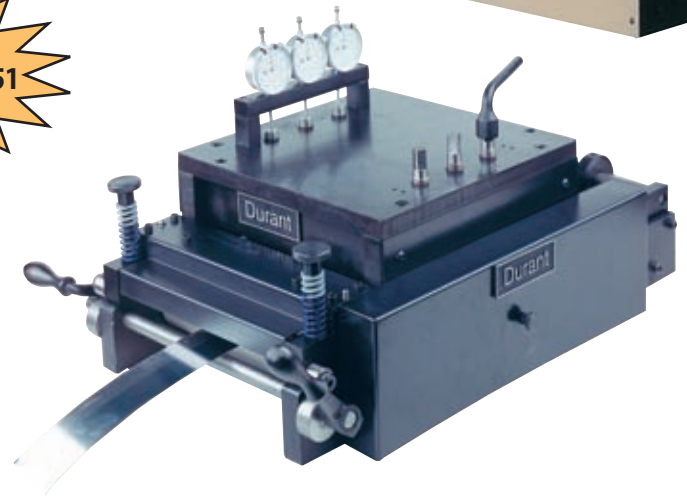

SS-10 Flat Stock Straightener

Pilot Release Pull Thru Straighteners . . .

Call Durant!

Flat Material Cut-To-Length Machines

The Compact, Economical, Efficient Cut-To-Length Machines...



MP-6-SCP



MP-12-SCP



HP-18-DHC

When making an investment in Cut-To-Length Machines, Durant is the solution for your requirements.

Durant is a team building the machine suited particularly for your application. Durant can provide you with our standard feed body and electronics package or make necessary modifications at a very reasonable cost. Durant manufactures Servo Roll Feeds that provide power, speed, and precision feed accuracy for all applications.

Durant Tool Company offers thirteen models. All feed body parts are precision manufactured with the latest CNC machine technology and have a black oxide machine tool finish. These low maintenance high performance machines incorporate the latest Servo technology.

The Durant DPC and DHC Series Pneumatic and Hydraulic Cutters are the ideal machines to use with Electronic Servo Feeds in Cut to Length operations. The Cut to Length line is mounted on a rugged machine base to give you a compact, portable cutting operation.

These powerful cutters are also utilized with power presses for scrap cutting.

Pneumatically or hydraulically powered, these cutters are designed to shear material at full width. The powerful triple acting air cylinder has a pancake profile for higher speed operation. Integral stroke dampeners are used to handle snap-through shock loads, extending cycle life.

The four-way solenoid valve controls the sequencing and can be synchronized with a press. If a timing relay or counter is used, every other press stroke operation is possible for longer scrap pieces or extremely high speed operations.

Each cutter is equipped with a material holding device for optimal cutting accuracy, adjustable material guides, air silencers and safety guard. Both upper and lower blades are vertically adjustable for wear compensation and sharpening. The lower blade is also horizontally adjustable to provide the correct blade clearance necessary to cut different materials.

The electronic control package consists of an operator interface keypad with the industries most user friendly software on the market today. The keypad contains various system performance data and accumulators.

Flat Material Cut-To-Length Machines

SELECTION

Durant manufactures thirteen standard models of high quality competitively priced Cut-To-Length Machines that handle applications to .200" thick mild steel and 24" wide material. When cutting plastic, foam, fiber or materials other than steel, material thickness is considerably greater than stated maximum material thickness. Please contact Durant.

VERSATILITY

Durant Cut-To-Length Machines are built to handle materials thick and thin, narrow or wide, flimsy or rigid in metal, plastic, foam or paper. If our standard specifications do not meet your requirements, call Durant.

ACCURACY

Durant's high quality CNC machined feed body exceeds the manufacturing specifications of all other Servo Feed manufacturers. Cluster gears are on top & bottom rolls for zero backlash regardless of material thickness.

Durant's Electronic controls are combined with the most accurate feed body, to give you, our customer, the premier Electronic Servo Feed.

CONSTRUCTION

Every model is engineered and machined from the latest CNC Technology and black oxide finished giving our customers the premier Electronic Servo Feed and cutter.

COMPARISON

Put our machines beside any other comparative unit you have heard about. We won't need to say anything more. You win with Durant! We win with you!

STANDARD MECHANICAL FEATURES

- Precision Machined construction.
- Black Oxide finished.
- Matte finish rolls.
- Zero maintenance sealed bearings.
- Cluster gears on top & bottom rolls for zero backlash regardless of material thickness.
- Zero maintenance low inertia pulley mounted with trantorque keyless bushing.
- Zero maintenance Kevlar belt which eliminates lubrication & wear.
- Brushless servo motor.
- Adjustable roller stock guides.
- Positive pressure die springs on upper roll.
- Cascade entry rolls.
- Heavy duty machine base built to customer specifications.
- Color: Ivory or customer to specify.

STANDARD ELECTRIC CONTROL FEATURES

- Control enclosure is a rugged 24x20x12" free standing NEMA 12 cabinet. MP cabinet is 20x16x8" deep.
- Operator control: Power On/Off selector switch, Emergency Stop push-pull button, Index push button, Auto/Manual/Jog to Length selector switch & remote forward / reverse jog station.
- Operator interface keypad and display.
- Electronic Control is wired to JIC and NEC standards.

CUT-TO-LENGTH MACHINES				
Model	Max Material Width	Max Material Thickness (Mild Steel)	Cutting Length	Input Power
MP-3 SCP	3"	.040"	0-999"	230 VAC
MP-6 SCP	6"	.046"	0-999"	230 VAC
VP-6 SCP	6"	.068"	0-999"	230 VAC
VP-6 CMN	6"	.125"	0-999"	230 VAC
MP-12 SCP	12"	.068"	0-999"	230 VAC
VP-12 SCP High Performance	12"	.068"	0-999"	230 VAC
VP-12 CMN	12"	.125"	0-999"	230 VAC
HP-12 DHC	12"	.187"	0-999"	230 VAC

CUT-TO-LENGTH MACHINES				
Model	Max Material Width	Max Material Thickness (Mild Steel)	Cutting Length	Input Power
VP-18 SCP High Performance	18"	.100"	0-999"	230 VAC
HP-18 DHC-A	18"	.160"	0-999"	230 VAC
HP-18 DHC-B	18"	.200"	0-999"	230 VAC
VP-24 SCP High Performance	24"	.090"	0-999"	230 VAC
HP-18 DHC	24"	.160"	0-999"	230 VAC

Roll Feeder / Flat Stock Straightener

Durant has the largest selection of Servo Roll Feeds with spacesaving, Pull Thru Stock Straighteners. All models are equipped with adjustable mounting stands/cabinets and Durant precision Stock Straighteners. Mechanical or Air Pilot Release on the straighteners is a very desirable option for many applications. Durant offers the Servo Roll Feeds for both flat stock straightening and wire straightening/feeding.

STANDARD MECHANICAL FEATURES

- Precision Machined construction, solid steel.
- Black Oxide finished.
- Matte finished rolls (Servo Feed).
- Zero maintenance sealed bearings (Servo Feed).
- Cluster gears on top & bottom rolls for zero backlash regardless of material thickness (Servo Feed).
- Zero maintenance low inertia pulley mounted with trantorque keyless bushing.
- Zero maintenance Kevlar belt which eliminates lubrication & wear.
- Brushless servo motor.
- Adjustable roller stock guides.
- Positive pressure die springs on upper roll.
- Casade entry rolls.
- Color: Ivory or customer to specify.
- Dial indicators (Straightener).

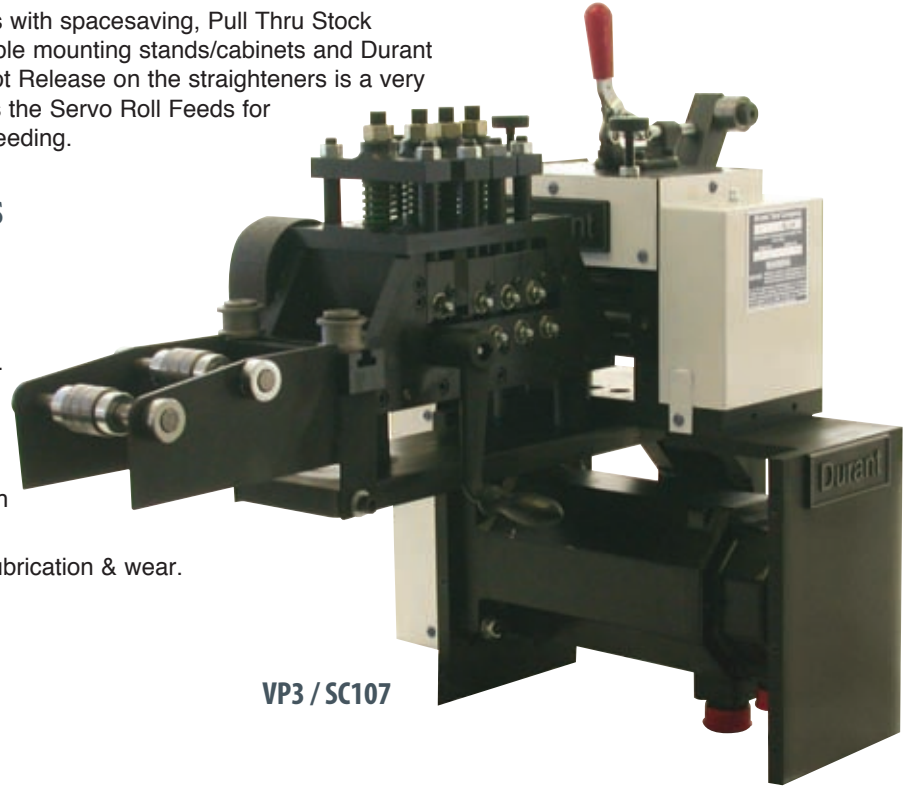

VP3 / SC107

STANDARD ELECTRIC CONTROL FEATURES

- Control enclosure is a rugged 24x20x12 free standing NEMA 12 cabinet. MP & VP cabinet is 20x16x8" deep.
- Operator control: Power On/Off selector switch, Emergency Stop push-pull button, Index push button, Auto/Manual/Jog to Length selector switch & remote forward / reverse jog station.
- Operator interface keypad and display.
- Electronic Control is wired to JIC and NEC standards.

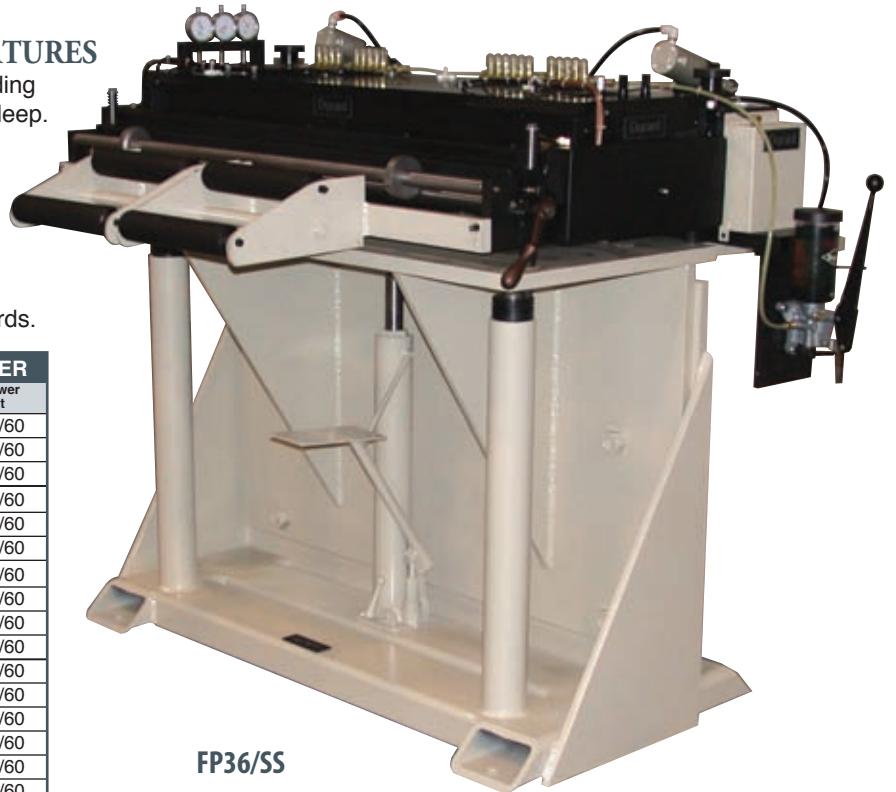

FP36/SS

FLAT STOCK SERVO WITH PULL THRU STRAIGHTENER					
Model	Max. Material Width	Max. Material Thickness	Feed Roll Diameter	No. Str. Rolls	AC Power Input
MP-3/SC107	3"	.040"	2"	7	230/1/60
MP-6/SC27	6"	.040"	2"	7	230/1/60
MP-12/SC57	12"	.040"	2"	7	230/1/60
VP-3/SC107	3"	.080"	2"	7	230/1/60
VP-6/SC27	6"	.080"	2"	7	230/1/60
VP-12/SS	12"	.080"	2"	5	230/1/60
VP-18/SS	18"	.062"	2"	5	230/1/60
VP-24/SS	24"	.062"	2"	5	230/1/60
VP-30/SS	30"	.062"	2"	5	230/1/60
VP-36/SS	36"	.062"	2"	5	230/1/60
FP-3/SS	3"	.110"	2.75"	5	230/1/60
FP-6/SS	6"	.100"	2.75"	5	230/1/60
FP-12/SS	12"	.100"	2.75"	5	230/1/60
FP-18/SS	18"	.080"	2.75"	5	230/1/60
FP-24/SS	24"	.065"	2.75"	5	230/1/60
FP-30/SS	30"	.060"	2.75"	5	230/1/60
FP-36/SS	36"	.055"	2.75"	5	230/1/60

All Durant Flat Stock Straighteners can be mounted on our Electronic Servo Feeds for a Compact, Space Saving Straightening / Feeding machine.



Durant Precise Air Feeders

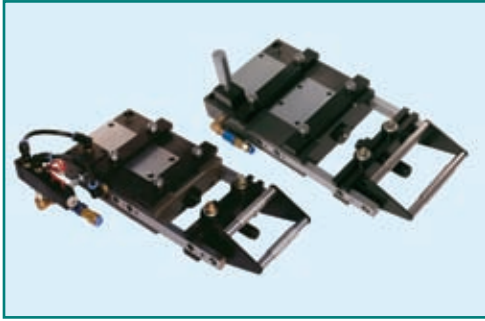

Mechanical Plunger Actuation

Electrical Actuation

PRECISE PRODUCTIVITY PERFORMERS

Durant provides the most cost effective precise pneumatic air feeders for your production requirements. Thirteen models are offered in material widths up to 12", maximum stroke length of 12", and steel thickness .100" maximum. Greater thickness may be used when feeding materials other than steel.

All Durant precise model air feeders include a (3) Year Warranty and Free "0" Ring Repair for the life on the air feeder. No confusing paperwork is required. Simply return the air feeder to Durant and we will repair the feeder at no charge to you.

Durant is not satisfied until you, our customer, is satisfied!

Each Durant precise air feeder is designed and manufactured to insure your feeding production runs smoothly.

SELECTION

You can feed materials up to 12" wide, 12" stroke length, and material thickness to .250" thick or greater.

VERSATILITY

Durant is built to see you through thick or thin, narrow or wide in metal, plastic or paper. Cost effective production always starts with Durant and ends at the bottom line.

COMPARISON

Put our Durant precise air feeder units beside any other comparative unit you have heard about. You will find our Durant Precise Air Feeder to be the most Cost Effective, Accurate, Feeding machine available.

CONSTRUCTION

Every model in the line is heavily, quality, manufactured to insure trouble free operation for the life of the Air Feeder.

INSTALLATION

Installation is a snap with Durant. Simply insert two bolts through mounting holes (standard air feed spacing), and bolt it to the press table or bolster plate. Next, fix a striker to the press ram and connect the air supply, (75 to 120 PSI). The second the striker is touched by the actuator on the feed, the feed goes into action. The feed length can be altered at any time by simply adjusting the stop on the air feed.

ACCURACY

Our sophisticated series of controls enables Durant to achieve accuracy of 0.001" for a couple of reasons. First of all, the feed material is always in the solid grip of either the feed clamp or the holding clamp so it cannot slip or misfeed. Secondly, even if it is maladjusted, the special shock absorbing air cushions at each end of the stroke prevent bounce.

Model	Max. Width	Max. Stroke	Max. Thickness	Max Strokes Per Minute	Pulling Capacity lbs.
AF 12	1.5"	2"	.040"	220	37
AF 16	1.5"	6"	.040"	60	37
AF 22	2.5"	2.5"	.048"	200	72
AF 28	2.5"	8"	.040"	50	72
AF 44	4"	4"	.092"	165	103
AF 412	4"	12"	.056"	50	138
AF 66	6"	6"	.092"	120	138
AF 612	6"	12"	.072"	45	175
AF 88	8"	8"	.092"	100	277
AF 106	10"	6"	.092"	100	277
AF 1010	10"	10"	.100"	65	351
AF 126	12"	6"	.100"	90	351
AF 1212	12"	12"	.100"	50	351

DURANT PRECISE PNEUMATIC AIR FEED OPTIONS

Pilot Release
Electrical Actuation

Are Air Feed Replacement Parts Costing You \$\$\$ and production time! Call Durant. We have the solution to your problems!

Durant Premium Air Feeders

Productivity Performers

To make sure your production facility can take advantage of the precision control and high speed effectiveness of the Durant Air Feed, we make 75 different models.

If you are making something small in metal, plastic or paper, look to our A-50. This unit offers a 2" maximum width, a 2" maximum stroke, a .079" maximum thickness, and can operate at speeds up to 270 strokes per minute. Of course, that is just where things start out. Where they end up is the Maxi Model TK3 which handles width up to 24" , with a maximum stroke of 12" , a maximum thickness of .100", and offers delivery capability of up to 40 units a minute. Every production need in between is covered.

When you look at Durant, you will be looking at a number of special features you are not likely to find anywhere else. All units are built with extra thick wear plates, dual air cushions, hardened heavy duty guide rails, and hardened brass cylinder liners.

To make your coil feeding even better, Durant Air Feeds come with a complete line of accessories. Each is designed to do its job perfectly ... each is designed to work perfectly with your Durant unit.

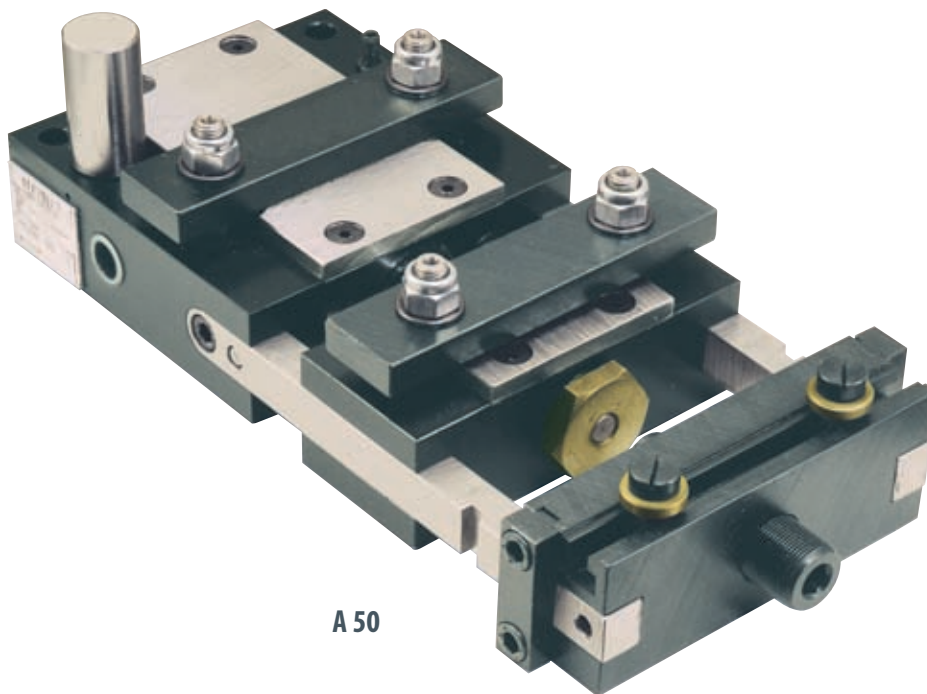

A 50

UNIQUE FEATURES FOUND ON ALL DURANT MODELS

- Dual air cushions for durability, quiet operation, and the elimination of hammering.
- Extra thick stainless wear plates on both main body and feeding body. Provides smoother faster operating rates, extended feed life, and enables the handling of unique wire and material configurations.
- Hardened brass bushings inside the main feed body reduce wear and failure associated with other air feeds.
- Oversized hardened guide rails.
- Oversized air pistons and feed grippers.
- Material support rollers.

SELECTION

Now you can feed materials from .002" to .200" thick. And widths as wide as 24". With 75 models available, Durant has a model just right for your application.

VERSATILITY

Durant is built to see you through thick or thin, narrow or wide, flimsy or rigid, in metal, plastic or paper. Cost effective production always starts with Durant...and ends at the bottom line.

COMPARISON

Put our Durant Air Feed units beside any other comparative unit you have heard about. We won't need to say anything more.

CONSTRUCTION

Every model in the line from standard to maxi is heavily constructed and totally sealed to insure trouble free operation, even in the most hostile factory environments.

INSTALLATION

Installation is a snap with Durant. Simply insert two bolts through mounting holes (standard air feed spacing), and bolt it to the press table or bolster plate. Next, fix a striker to the press ram and connect the air supply, (75 to 120 PSI). The second the striker is touched by the actuator on the feed, the feed goes into action. The feed length can be altered at any time by simply adjusting the stop on the air feed.

ACCURACY

Our sophisticated series of controls enables Durant to achieve accuracy of 0.001" for a couple of reasons. First of all, the feed material is always in the solid grip of either the feed clamp or the holding clamp so it cannot slip or misfeed. Secondly, even if it is maladjusted, the special shock absorbing air cushions at each end of the stroke prevent bounce.

Are Air Feed Replacement Parts Costing You \$\$\$ And Production Time?

Call Durant!

We Have The Solution To Your Problems!



Durant Premium Air Feeders

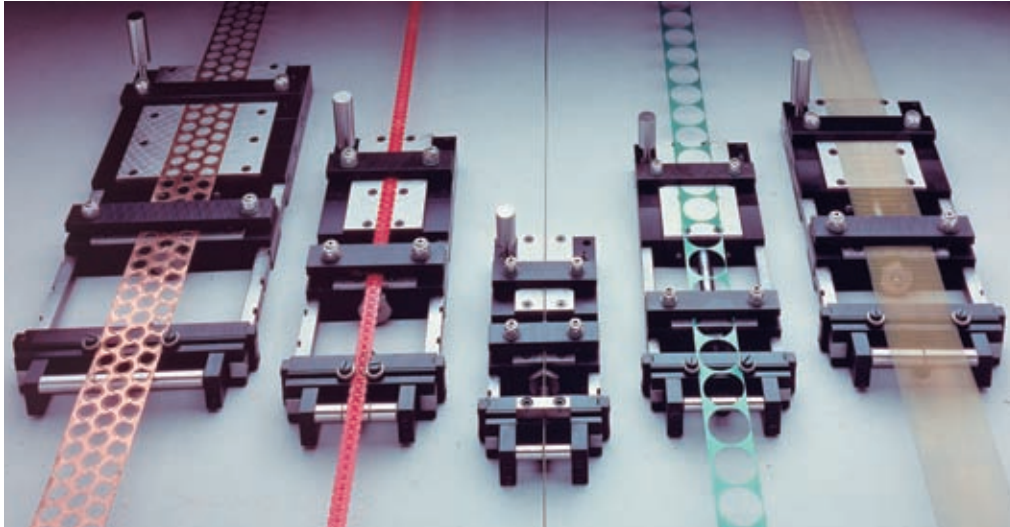

Standard Models

The standard models are especially suited for feeding narrow materials less than 4" in width and .079" thickness.

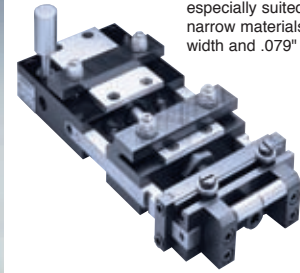

Heavy Duty Model

The Heavy Duty Series incorporates unique engineering features with pulling capacities of 238 lbs. and 475 lbs. and material widths to 24".

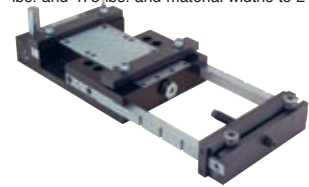

Accessories for Greater Productivity!

Filter - Regulator - Lubricator:

Regulate, filter, and lubricate the flow of air to the feed. Recommended for all applications.

Stock Clamp-Pilot Release:

When pilot pins are located in your dies, stock clamp pilot release is required. Both spring actuated and electric actuated available.

Electric Actuation:

For feed lengths longer than 6", or other applications where conventional actuation is impractical, this unit will take care of your problems. Available in 115 volts or 220 volts.

Operator Safety Guard:

Steel reinforced protection device - Recommended for all models.

Thin Material Guiding Device:

Recommended for .002" to .010" thick material that may tend to buckle.

Multi Stroke Actuation:

For applications that require longer lengths of feed than the model permits with a single stroke.

REMOTE AIR ACTUATION:

Another alternative actuation technique.

Stock Straightener Attachment:

Stock Straighteners can be added to all model air feeds providing a modular space-saving combination unit for both straightening and feeding.

Stock Oiler Attachment:

Modular stock oilers can be added to all model air feeds at a small additional cost. "Durant Thin Line" stock oilers add long life to your tooling and dies.

Note: Durant stock oilers can be fitted to all manufacturers' air feeds or roll feeds.

Model	Maximum Strip Width (Inches)	Maximum Stroke (Inches)	Maximum Strip Thickness	Strokes Per Minute	Pulling Capacity (Pounds)
STANDARD MODELS					
A 50	2	2	.079	280	53
A 100	2	4	.075	200	53
A 150	2	6	.067	160	53
A 200	2	8	.060	130	53
A 250	2	10	.047	110	53
B 50	3	2	.079	260	53
B 100	3	4	.071	190	53
B 150	3	6	.060	150	53
B 200	3	8	.055	110	53
B 250	3	10	.051	90	53
C 50	4	2	.067	210	53
C 100	4	4	.062	160	53
C 150	4	6	.062	120	53
C 200	4	8	.051	90	53
C 250	4	10	.047	80	53
MIDDLE MODELS					
BX 50	3	2	.110	260	100
BX 100	3	4	.106	180	100
BX 150	3	6	.094	150	100
BX 200	3	8	.079	120	100
BX 250	3	10	.079	90	100
CX 50	4	2	.094	240	100
CX 100	4	4	.083	170	100
CX 150	4	6	.071	140	100
CX 200	4	8	.065	110	100
CX 250	4	10	.065	90	100
DX 50	6	2	.075	220	100
DX 100	6	4	.075	160	100
DX 150	6	6	.075	140	100
DX 200	6	8	.065	110	100
DX 250	6	10	.050	90	100
HEAVY DUTY MODELS					
P 1	6	4	.165	140	238
P 2	6	8	.165	120	238
P 3	6	12	.165	70	238
S 1	8	4	.120	140	238
S 2	8	8	.120	120	238
S 3	8	12	.120	70	238
Z 1	12	4	.120	140	238
Z 2	12	8	.120	120	238
Z 3	12	12	.100	70	238
V 1	18	4	.120	120	475
V 2	18	8	.100	100	475
V 3	18	12	.080	80	475
V 4	18	16	.070	60	475
K 1	24	4	.100	110	475
K 2	24	8	.080	95	475
K 3	24	12	.070	75	475
K 4	24	16	.060	55	475
MAXI MODELS					
TZ 1	12	4	.200	115	710
TZ 2	12	8	.180	80	710
TZ 3	12	12	.160	60	710
TK 1	24	4	.140	80	710
TK 2	24	8	.120	75	710
TK 3	24	12	.100	40	710

Typical Application

Typical standard model application with plunger type actuation and die mounted feed.

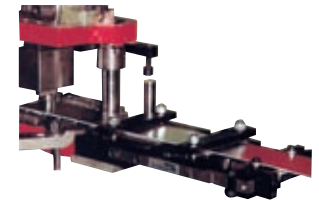

Operator Safety Guard

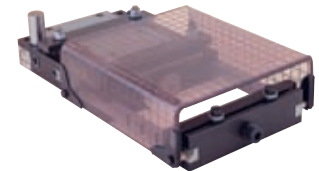

Electric Actuation Pilot Release Clamp

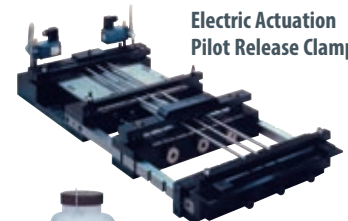

Stock Oiler



Material Lubricators

Keep Your Material Running Smoothly!

Slim Style Stock Lubricator

Features and Benefits:

- Oil can be supplied evenly and thinly to the upper and lower surfaces of the material, prolonging the life of your tools.
- This machine is equipped with two rollers, upper and lower. Oil can be precisely positioned on each part of your tool as required.
- A filter screen is located in the oil supply reservoir allowing for re-use.
- Both the upper and lower rollers are made of high quality and density felt.
- Installation in two minutes!
- Aluminum alloy body and its surface is protected with a specialized treatment that is extremely durable.
- A mounting bracket is included which is suitable for all installations.
- Adjustable valves precisely control oil flow onto rollers, preventing over lubricating and waste of oil.
- Optional electric pump and 2.6 gallon tank allows for automatic timing with your press.

**DAT-150
Mounted on Roll Feeder**



SLIM STYLE STOCK OILER				
MODEL	MAX. MATERIAL WIDTH	MATERIAL THICKNESS	MACHINE THICKNESS	MACHINE HEIGHT
DAT 65	2 1/2"	.004 - .240	1 3/4"	6"
DAT 80	3"	.004 - .240	1 3/4"	6"
DAT 100	4"	.004 - .240	1 3/4"	6"
DAT 150	6"	.004 - .240	1 3/4"	6"
DAT 200	8"	.004 - .240	1 3/4"	6"
DAT 250	10"	.004 - .240	1 3/4"	6"
DAT 300	11 3/4"	.004 - .240	1 3/4"	6"
DAT 400	15 3/4"	.004 - .240	1 3/4"	6"
DAT 500	19 3/4"	.004 - .240	1 3/4"	6"
DAT 600	23 1/2"	.004 - .240	1 3/4"	6"
DAT 700	27 1/2"	.004 - .240	1 3/4"	6"
DAT 800	31 1/2"	.004 - .240	1 3/4"	6"
DAT 1000	39 1/2"	.004 - .240	1 3/4"	6"

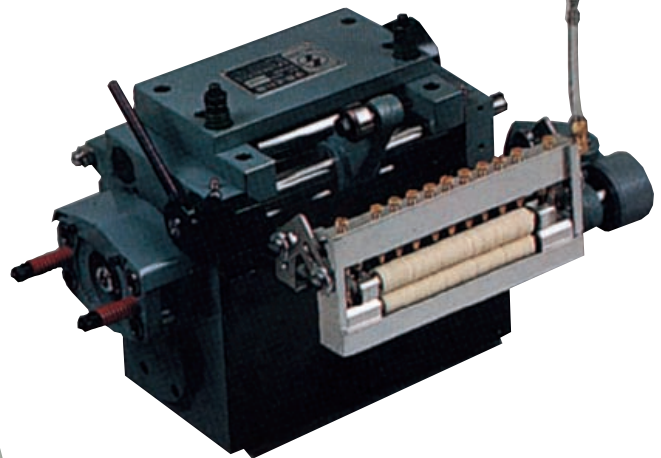

Can be installed on all Air Feeds, Roll Feeds and other types of machinery.

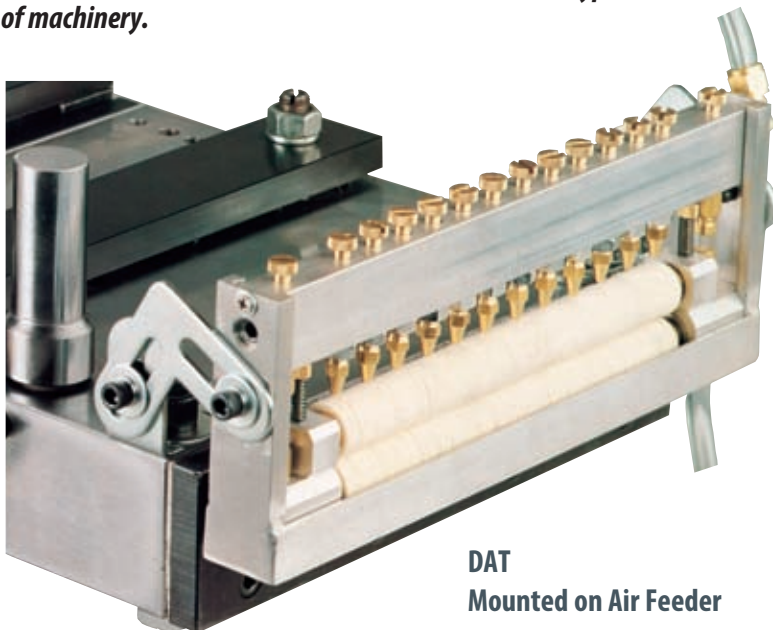

**DAT
Mounted on Air Feeder**

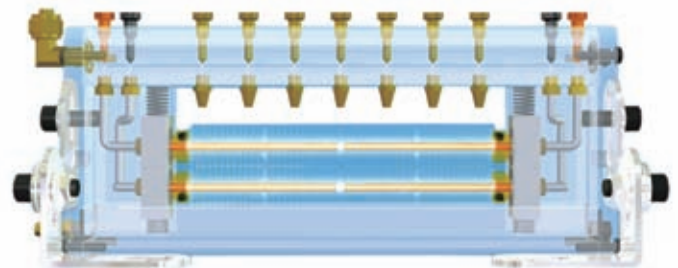

Material Lubricators

Options



SD1 standard accessories included with all lubricators



Options 1 DET Lubricant tank with electromagnet valve and level switch:

The lubricant tank equipped with electromagnet valve is capable of feeding the lubricant synchronously with the press. It lubricates when the press is in operation, and stops feeding oil when the press stops. Connected to the press control, it stops the press when the lubricant tank is out of oil. (Voltage of electromagnetic valve: 110V or 220V)



Options 2 DSET 1 Stainless lubricant tank with electromagnet valve:

The lubricant tank equipped with electromagnet valve is capable of feeding the lubricant synchronously connected to the press control system. It lubricates when the press is in operation, and stops feeding oil when the press stops. (Voltage of electromagnetic valve: 110V or 220V)



2.6 gallon tank

Options 3 DAT1 Electrical pump oil tank

The electrical pump oil tank can be connected to the press control system for simultaneous oiling. It automatically feeds oil when the press is operating and stops feeding oil when the press stops. (Voltage of the electrical pump: 110V, 220V or 380V)

Uncoilers & Pallet Decoilers

When your uncoiling application calls for pallet decoilers, it's time to call Durant. Why?

1. Durant has more than 75 years experience in uncoiling all types of materials in probably every type of application.
2. Durant manufactures the largest selection of pallet decoilers and also vertical (traditional) uncoilers.
3. Durant offers a standard 3 year warranty on all uncoilers.
4. Durant product engineering, quality, manufacturing and components are rated #1.
5. Durant pricing is always at the most competitive levels.
6. Durant customer service specialists are a team focusing on your needs. We're not satisfied until you are!

Features:

- No dangerous turntable pinch points (Note: Other manufacturers have many casters and drive wheels under turntable creating dangerous pinch point for operator's fingers.)
- Heavy duty, rugged turntable and base construction.
- 3 year warranty.
- Reverse turntable direction rotation with flip of the switch. No mechanical adjustments or torque systems to install.
- No drive wheels or casters to clean or replace.
- Easy loading of entire pallets of coil stock.
- Requires no slack loop. Can be placed within 2 feet of press.
- Models to 12,000 lb. capacity.
- Speeds to 70 RPM.
- Turntable diameters to 72" O.D.
- Special material guide drums to 24" wide.
- Urethane drum option.
- Coil lock option.
- Rubber anti-slip turntable mat option.
- Special sizes to customer specifications.
- Custom paint colors to customer specifications.
- Quick response regenerative drive that enhance acceleration and deceleration option.
- Versatile machine that handles most press, roll forming, and wire forming applications.

Automatic Speed Control

Reverse Turntable
with Flip of the Switch

Manual Speed Control
Override Feature

Rugged 1/2" Thick
Solid Steel Turntable
(Will not Deflect or Dent
with Forklift Loading)

Heavy Duty Gear Box
No Drive Wheels to Replace

(2) Heavy Duty Bearings

From
\$3900⁰⁰



Model #3525-42

Uncoilers & Pallet Decoilers

PALLET DECOILER SPECIFICATIONS

Model	Weight Capacity	Max. Turntable RPM	Turntable Diameter	Motor H.P.
512-30	500 lbs.	0-12	30"	1/2
525-30	500 lbs.	0-25	30"	1/2
550-30	500 lbs.	0-50	30"	1/2
512-36	500 lbs.	0-12	36"	1/2
525-36	500 lbs.	0-25	36"	1/2
550-36	500 lbs.	0-50	36"	1/2
1212-30	1200 lbs.	0-12	30"	1/2
1225-30	1200 lbs.	0-25	30"	1/2
1250-30	1200 lbs.	0-50	30"	1/2
1212-36	1200 lbs.	0-12	36"	1/2
1225-36	1200 lbs.	0-25	36"	1/2
1250-36	1200 lbs.	0-50	36"	1/2
1212-42	1200 lbs.	0-12	42"	1/2
1225-42	1200 lbs.	0-25	42"	1/2
1250-42	1200 lbs.	0-50	52"	1/2
3512-42	3500 lbs.	0-12	42"	1/2
3525-42	3500 lbs.	0-25	42"	1/2
3550-42	3500 lbs.	0-50	42"	1/2
5012-42	5000 lbs.	0-12	42"	1
5025-42	5000 lbs.	0-25	42"	1
5050-42	5000 lbs.	0-50	42"	1
5012-48	5000 lbs.	0-12	48"	1
5025-48	5000 lbs.	0-25	48"	1
5050-48	5000 lbs.	0-50	48"	1
6012-48	6000 lbs.	0-12	48"	1
6025-48	6000 lbs.	0-25	48"	1
6050-48	6000 lbs.	0-50	48"	1
7512-52	7500 lbs.	0-12	52"	2
7525-52	7500 lbs.	0-25	52"	2
7550-52	7500 lbs.	0-50	52"	2
7512-60	7500 lbs.	0-12	60"	2
7525-60	7500 lbs.	0-25	60"	2

PALLET DECOILER SPECIFICATIONS

Model	Weight Capacity	Max. Turntable RPM	Turntable Diameter	Motor H.P.
7550-60	7500 lbs.	0-50	60"	2
8512-60	8500 lbs.	0-12	60"	2
8525-60	8500 lbs.	0-25	60"	2
10M-12-60	10,000 lbs.	0-12	60"	3
10M-25-60	10,000 lbs.	0-25	60"	3
12M-12-60	12,000 lbs.	0-12	60"	5
12M-25-60	12,000 lbs.	0-25	60"	5

Options:

- Coil lock.
- Rubber anti-slip turntable covering.
- Stock straightener.
- Customer specified turntable diameter.
- Regenerative drive/braking.
- Special color (black standard).
- Larger weight capacity to 12,000 lbs.
- Faster turntable speed to 70 RPM.
- Wider material stock drum to 24".
- Urethane drum.
- Casters for mobility and portability.
- Zero Speed/E Stop Air Brake system.

Turntable Diameters:

30", 36", 42", 48", 52", 60", 72"

Benefits:

- Increase Worker Productivity.
- Easy Loading of Full Pallets of Coils.
- Smooth Payout and Uncoiling of your material.
- Heavy Duty Steel Frame Construction for Long Trouble Free Operation.
- Highest Quality Components.
- (3) Year Warranty.
- Versatile machine that handles many Uncoiling applications.



"N" Series Pallet Decoilers

Durant has the pallet decoiler for every need...thin delicate flat stock or wire, heavy duty wire, and flat coiled material to 24". Whether your pallets weigh 500 lbs. or up to 12,000 lbs., call Durant for the appropriate machine to handle your requirements. What will you, our customer receive? When you purchase a Durant pallet decoiler, you get the highest quality, heavy duty, most advanced pallet decoiler available from any manufacturer. Durant electrical controls are simple and safe to operate with most operating features not matched by competitive models. Durant pallet decoilers have the highest horse power rating in their class. Durant pallet decoilers feature heavy duty gear boxes not matched by any competitor. Durant has more than 75 years of uncoiling experience in both horizontal and vertical decoilers. All Durant products have an unquestioned 3 year guarantee. If you are looking for pallet decoilers, look to Durant "the leader in pallet decoiler technology."

FEATURES:

- Adjustable Acceleration/Deceleration
- Speed Control Sensor: No Potentiometers
- Emergency Stop Circuit: Standard
- Quick Adjust Material Roller for height of coils
- Heavy Duty Steel Frame Construction
- Quick Coil Height Adjustment Feature With Hand Wheel
- Rugged 1/2" Thick Solid Steel Turntable. Will not deflect or dent with forklift loading
- (2) Heavy Duty Main Spindle Support Bearings
- Heavy Duty Gear Reducer
- Quick Response Regenerative Drive
- Reverse Turntable direction with flip of the switch. No mechanical adjustments or torque systems to install
- No drive wheels that wear and slip
- Requires no slack loop. Can be placed within 2 feet of the press depending on the application
- Easy loading of entire pallets of coil stock
- Easy to move within factory
- Automatic material speed controller
- Manual speed control over ride feature
- No Dangerous Turntable Pinch Points. (Note: Other manufacturers have many casters and drive wheels under the turntable creating dangerous pinch points for operator's fingers.)
- No Potentiometers to fail or break

OPTIONS:

- Faster Turntable speeds to 75RPM
- Turntable Diameters to 72" O.D.
- Special material widths to 24"
- Urethane Drum option
- Coil Lock Option
- Rubber Anti-Slip Turntable Mat Option
- Custom Paint Colors to Customer Specifications
- Casters for mobility and portability
- Zero Speed/E Stop Air Brake system

BENEFITS:

- Increase Worker Productivity
- Easy Loading of Full Pallets of Coils
- Smooth Payout and Uncoiling of your material
- Heavy Duty Steel Frame Construction for Long Trouble Free Operation
- Highest Quality Components
- (3) Year Warranty
- Versatile machine that handles many Uncoiling applications

Model	Weight Capacity	RPM	Turntable Diameter
N 512-30	500 lbs.(227 kg)	0-12	30" (762 mm)
N 525-30	500 lbs.(227 kg)	0-25	30" (762 mm)
N 550-30	500 lbs.(227 kg)	0-50	30" (762 mm)
N 512-36	500 lbs.(227 kg)	0-12	36" (1080 mm)
N 525-36	500 lbs.(227 kg)	0-25	36" (1080 mm)
N 550-36	500 lbs.(227 kg)	0-50	36" (1080 mm)
N 1212-30	1200 lbs.(546 kg)	0-12	30" (762 mm)
N 1225-30	1200 lbs.(546 kg)	0-25	30" (762 mm)
N 1250-30	1200 lbs.(546 kg)	0-50	30" (762 mm)
N 1212-36	1200 lbs.(546 kg)	0-12	36" (1080 mm)
N 1225-36	1200 lbs.(546 kg)	0-25	36" (1080 mm)
N 1250-36	1200 lbs.(546 kg)	0-50	36" (1080 mm)
N 1212-42	1200 lbs.(546 kg)	0-12	42" (1067 mm)
N 1225-42	1200 lbs.(546 kg)	0-42	42" (1067 mm)
N 1250-42	1200 lbs.(546 kg)	0-42	42" (1067 mm)
N 3512-42	3500 lbs.(1591 kg)	0-12	42" (1067 mm)
N 3525-42	3500 lbs.(1591 kg)	0-25	42" (1067 mm)
N 3550-42	3500 lbs.(1591 kg)	0-50	42" (1067 mm)
N 5012-42	5000 lbs.(2273 kg)	0-12	42" (1067 mm)
N 5025-42	5000 lbs.(2273 kg)	0-25	42" (1067 mm)
N 5050-42	5000 lbs.(2273 kg)	0-50	42" (1067 mm)
N 5012-48	5000 lbs.(2273 kg)	0-12	48" (1219 mm)
N 5025-48	5000 lbs.(2273 kg)	0-25	48" (1219 mm)
N 5050-48	5000 lbs.(2273 kg)	0-50	48" (1219 mm)
N 6012-48	6000 lbs.(2727 kg)	0-12	48" (1219 mm)
N 6025-48	6000 lbs.(2727 kg)	0-25	48" (1219 mm)
N 6050-48	6000 lbs.(2727 kg)	0-50	48" (1219 mm)
N 7512-52	7500 lbs.(3409 kg)	0-12	52" (1321 mm)
N 7525-52	7500 lbs.(3409 kg)	0-25	52" (1321 mm)
N 7550-52	7500 lbs.(3409 kg)	0-50	52" (1321 mm)
N 7512-60	7500 lbs.(3409 kg)	0-12	60" (1524 mm)
N 7525-60	7500 lbs.(3409 kg)	0-25	60" (1524 mm)
N 7550-60	7500 lbs.(3409 kg)	0-50	60" (1524 mm)
N 8512-60	8500 lbs.(3864 kg)	0-12	60" (1524 mm)
N 8525-60	8500 lbs.(3864 kg)	0-25	60" (1524 mm)
N 10M-12-60	10,000 lbs.(4546 kg)	0-12	60" (1524 mm)
N 10M-25-60	10,000 lbs.(4546 kg)	0-25	60" (1524 mm)
N 12M-12-60	12,000 lbs.(5455 kg)	0-12	60" (1524 mm)

TURNTABLE DIAMETERS:

30", 36", 42", 48", 52", 60", 72"



"N" Series Pallet Decoilers

**"N" SERIES
HEAVY DUTY
PALLET DECOILER**

SPECIAL FEATURES INCLUDE:

1. Heavy duty, rugged, base construction
2. Ideal for thin material
3. Quick height adjustment feature allows material roller to be moved smoothly and accurately with hand wheel.
4. No potentiometers to fail or break. Only Durant uses a state of the art sensor in place of potentiometers.
5. Quick response regenerative drive that enhances acceleration and deceleration is standard equipment on all models.
6. Adjustable acceleration and deceleration.
7. Emergency stop circuit.
8. Largest motor H.P. in its class.
9. Advanced and user friendly controls. The most flexibility to handle all applications.
10. Table rotation can be reversed with the flip of a switch.
11. Easy to move within factory.

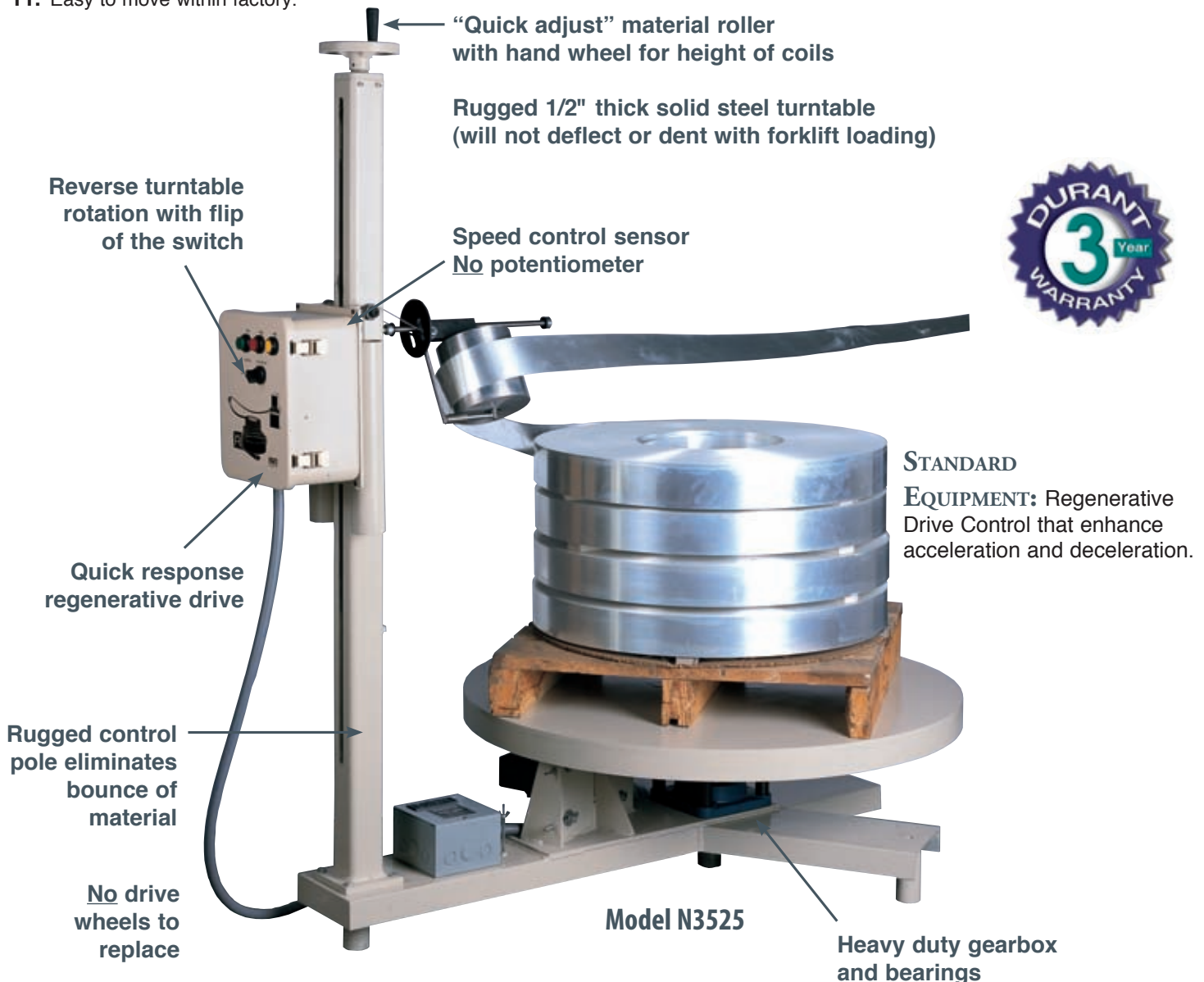

"R" Series Pallet Decoilers

Save time, space and ensure workers' safety

The simply efficient production performer that is easy to load.
Perfect for flat materials, wire, and thin narrow delicate stocks.

Durant has the pallet decoiler for every need...thin delicate flat stock or wire, heavy duty wire, and flat coiled material to 24". Whether your pallets weigh 500 lbs. or up to 12,000 lbs., call Durant for the appropriate machine to handle your requirements. What will you, our customer receive? When you purchase a Durant pallet decoiler, you get the highest quality, heavy duty, most advanced pallet decoiler available from any manufacturer. Durant electrical controls are simple and safe to operate with most operating features not matched by competitive models. Durant pallet decoilers have the highest horse power rating in their class. Durant pallet decoilers

feature heavy duty gear boxes not matched by any competitor. Durant has more than 75 years of uncoiling experience in both horizontal and vertical decoilers. All Durant products have an unquestioned 3 year guarantee. If you are looking for pallet decoilers, look to Durant "the leader in pallet decoiler technology."

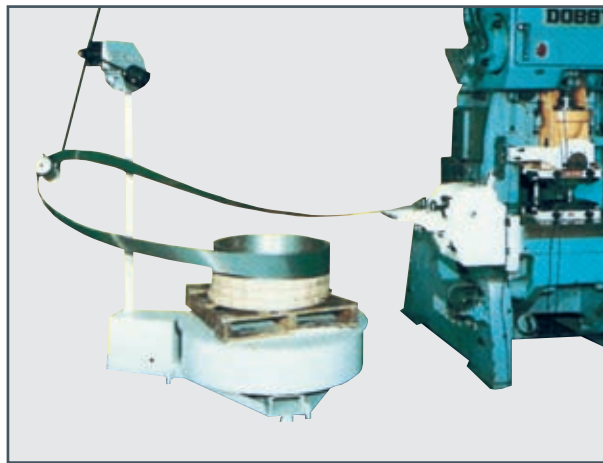

Uncoils in speeds up to 75 RPM and weight capacities to 12,000 lbs.

Unique "R" series system, allows coiled material to be used as delivered on pallets, saves space and insures workers safety. Powered by state-of-the-art variable speed, enclosed motor, that can't fill with metal chips or factory dirt. Reverse direction with flip of toggle switch. Requires only 52" installation space. Place within three feet of press feed in most applications since it doesn't need long loop for control of uncoiling speed.

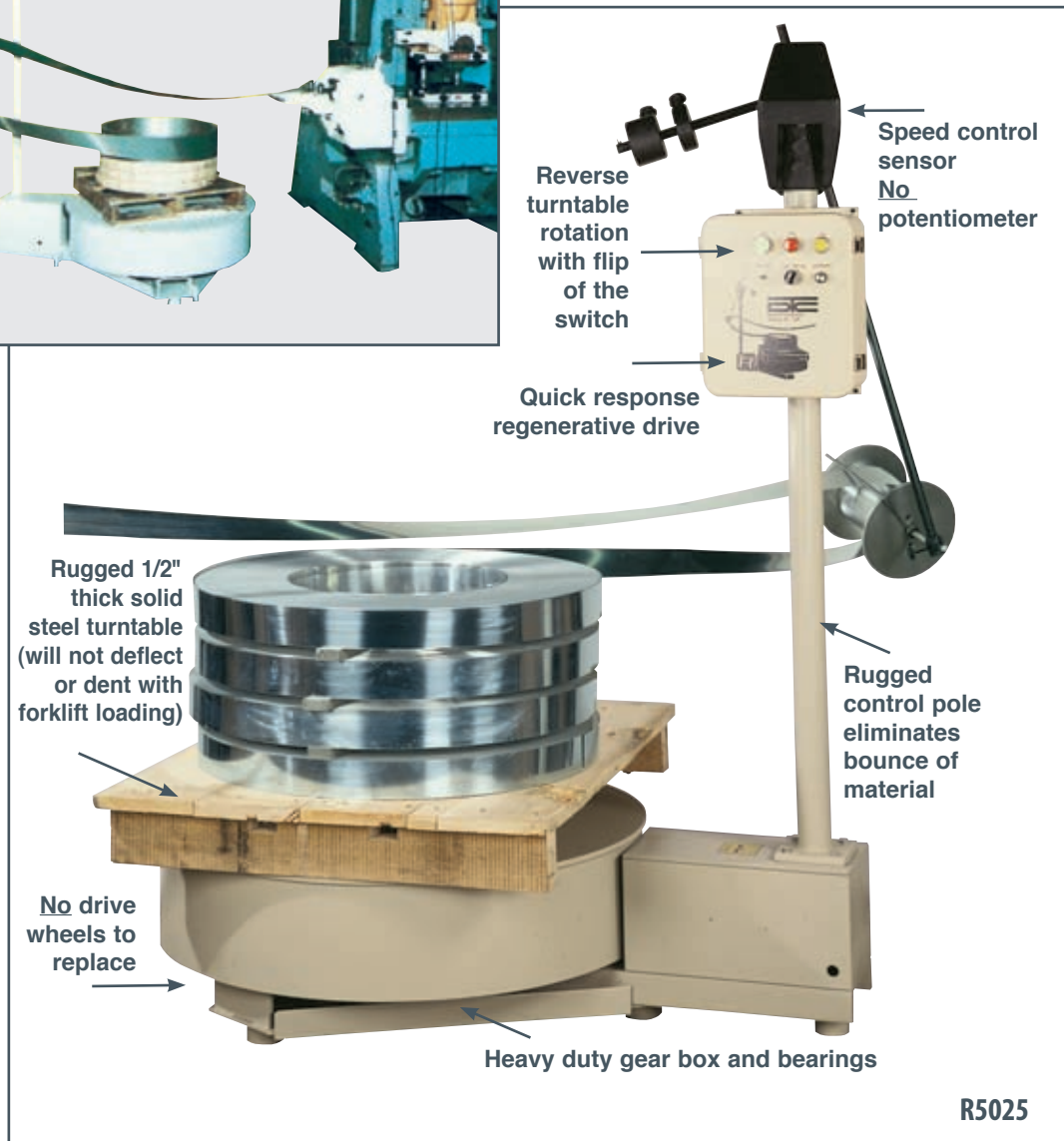

R5025



"R" Series Pallet Decoilers

Uncoil flat material to 24" wide, wire and delicate, thin, narrow materials less than 3/4" in width.

FEATURES:

- Adjustable Acceleration/Deceleration
- Speed Control Sensor: No Potentiometers
- Emergency Stop Circuit: Standard
- Quick Adjust Material Roller for height of coils: Standard
- Heavy Duty Steel Frame Construction
- Quick Coil Height Adjustment Feature
- Rugged 1/2" Thick Solid Steel Turntable. Will not deflect or dent with forklift loading
- (2) Heavy Duty Main Spindle Support Bearings
- Heavy Duty Gear Reducer
- Quick Response Regenerative Drive
- Reverse Turntable direction with flip of the switch. No mechanical adjustments or torque systems to install
- No drive wheels that wear and slip
- Requires no slack loop. Can be placed within 2 feet of the press depending on the application
- Easy loading of entire pallets of coil stock
- Easy to move within factory
- Automatic material speed controller
- Manual speed control over ride feature
- No Dangerous Turntable Pinch Points. (Note: Other manufactures have many casters and drive wheels under the turntable creating dangerous pinch points for operator's fingers.)
- No Potentiometers to Fail or Break

COMPARISON:

- Unique electronic controls allow for Durant "R" Series Pallet Decoiler to Increase and Decrease in speed quickly as your Press demands without any over travel or coasting associated with other models in its respective class. This feature permits Pallet Decoiler to be located as close as 3ft to the press.
- Table rotation can be reversed by the flip of a switch without any physical changes to the machine.
- Control Arm sensitivity can be adjusted easily by a hand knob without changing weights.
- Start, Stop, Jog, Forward-Reverse & Auto-Manual are standard features of the control system for ease of operation and operator safety.

OPTIONS:

- Faster Turntable speeds to 75RPM
- Turntable Diameters to 72" O.D.
- Special material widths to 24"
- Urethane Drum Option
- Coil Lock Option
- Rubber Anti-Slip Turntable Mat Option
- Custom Paint Colors to Customer Specifications
- Casters for mobility and portability
- Zero Speed/E Stop Air Brake system

BENEFITS:

- Increase Worker Productivity
- Easy Loading of Full Pallets of Coils
- Smooth Payout and Uncoiling of your material
- Heavy Duty Steel Frame Construction for Long Trouble Free Operation
- Highest Quality Components
- (3) Year Warranty
- Versatile machine that handles many Uncoiling applications

Model	Weight Capacity	RPM	Turntable Diameter
R 512-30	500 lbs.(227 kg)	0-12	30" (762 mm)
R 525-30	500 lbs.(227 kg)	0-25	30" (762 mm)
R 550-30	500 lbs.(227 kg)	0-50	30" (762 mm)
R 512-36	500 lbs.(227 kg)	0-12	36" (1080 mm)
R 525-36	500 lbs.(227 kg)	0-25	36" (1080 mm)
R 550-36	500 lbs.(227 kg)	0-50	36" (1080 mm)
R 1212-30	1200 lbs.(546 kg)	0-12	30" (762 mm)
R 1225-30	1200 lbs.(546 kg)	0-25	30" (762 mm)
R 1250-30	1200 lbs.(546 kg)	0-50	30" (762 mm)
R 1212-36	1200 lbs.(546 kg)	0-12	36" (1080 mm)
R 1225-36	1200 lbs.(546 kg)	0-25	36" (1080 mm)
R 1250-36	1200 lbs.(546 kg)	0-50	36" (1080 mm)
R 1212-42	1200 lbs.(546 kg)	0-12	42" (1067 mm)
R 1225-42	1200 lbs.(546 kg)	0-42	42" (1067 mm)
R 1250-42	1200 lbs.(546 kg)	0-42	42" (1067 mm)
R 3512-42	3500 lbs.(1591 kg)	0-12	42" (1067 mm)
R 3525-42	3500 lbs.(1591 kg)	0-25	42" (1067 mm)
R 3550-42	3500 lbs.(1591 kg)	0-50	42" (1067 mm)
R 5012-42	5000 lbs.(2273 kg)	0-12	42" (1067 mm)
R 5025-42	5000 lbs.(2273 kg)	0-25	42" (1067 mm)
R 5050-42	5000 lbs.(2273 kg)	0-50	42" (1067 mm)
R 5012-48	5000 lbs.(2273 kg)	0-12	48" (1219 mm)
R 5025-48	5000 lbs.(2273 kg)	0-25	48" (1219 mm)
R 5050-48	5000 lbs.(2273 kg)	0-50	48" (1219 mm)
R 6012-48	6000 lbs.(2727 kg)	0-12	48" (1219 mm)
R 6025-48	6000 lbs.(2727 kg)	0-25	48" (1219 mm)
R 6050-48	6000 lbs.(2727 kg)	0-50	48" (1219 mm)
R 7512-52	7500 lbs.(3409 kg)	0-12	52" (1321 mm)
R 7525-52	7500 lbs.(3409 kg)	0-25	52" (1321 mm)
R 7550-52	7500 lbs.(3409 kg)	0-50	52" (1321 mm)
R 7512-60	7500 lbs.(3409 kg)	0-12	60" (1524 mm)
R 7525-60	7500 lbs.(3409 kg)	0-25	60" (1524 mm)
R 7550-60	7500 lbs.(3409 kg)	0-50	60" (1524 mm)
R 8512-60	8500 lbs.(3864 kg)	0-12	60" (1524 mm)
R 8525-60	8500 lbs.(3864 kg)	0-25	60" (1524 mm)
R 10M-12-60	10,000 lbs.(4546 kg)	0-12	60" (1524 mm)
R 10M-25-60	10,000 lbs.(4546 kg)	0-25	60" (1524 mm)
R 12M-12-60	12,000 lbs.(5455 kg)	0-12	60" (1524 mm)
R 12M-25-60	12,000 lbs.(5455 kg)	0-25	60" (1524 mm)

If these specifications do not meet your requirements, call Durant.

We can alter our standard machine or build special for your specific needs.



Unwind / Rewind Reels

Solid Shaft Unwind / Rewind Reels



Dual Spindle VS-DMD-R
Rewind Machine with
Paper Interleaf Unwind
Spindle Option

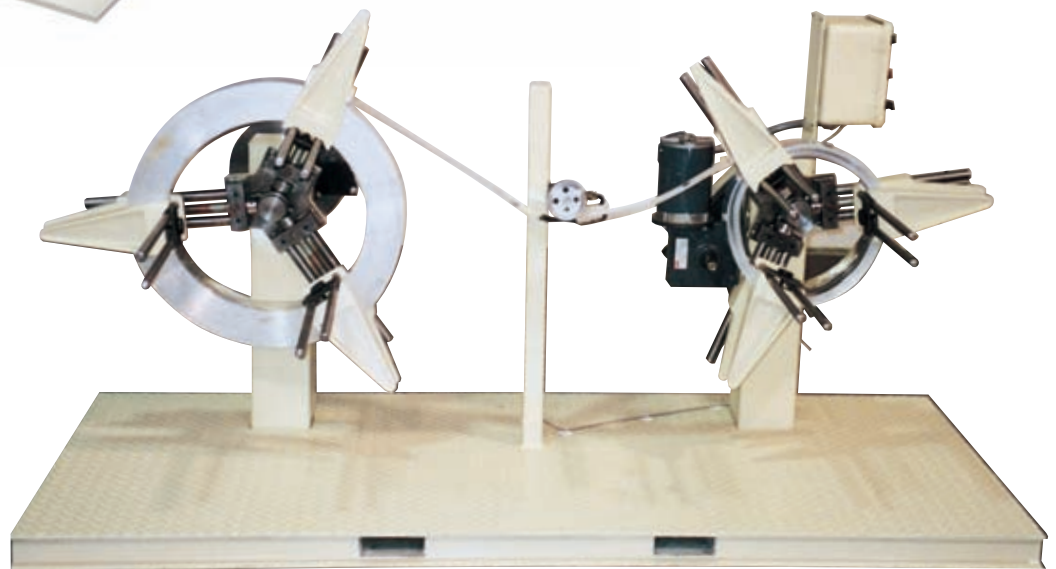

Reel-To-Reel
Winding with
Linear Measuring Machine

Unwind / Rewind Reels

Keep your production on a roll.

Solid Shaft Variable Speed Unwind/ Rewind Reel

The VS-DMD Variable Speed Unwind/Rewind Reels are designed specifically for applications that handle narrow, thin materials on spools.

As the unwind model, the machine has a variable speed dancer loop controller to smoothly payout your material, maintaining a predetermined loop of stock. An optional variable speed antenna type loop control is available.

The rewind model smoothly takes up your material utilizing an adjustable slip clutch to maintain tight coils when rewinding.

Durant offers many options including paper interleaf spindles, customer specified shaft diameters, and customer specified coil discs diameters, ultrasonic loop controls and dual spindle machines.

PRODUCT FEATURES:

- Heavy Duty Steel Frame Construction
- (2) Aluminum Spool Retaining Discs to Customer Specifications
- Main Shaft Diameter to Customer Specifications
- (2) Heavy Duty Main Spindle Bearings
- Heavy Duty Gear Reducer
- Variable Speed Dancer Type Material Loop Control on Unwind Models
- Adjustable Tension Slip Clutch to Maintain Tight Coils when Rewinding on Rewind Models

OPTIONS:

- Variable Speed Antenna Type Loop Control
- A-1 Sonic Type No Touch Loop Controller
- Special Spool Retaining Discs in Aluminum or Steel Plate
- Special Main Shaft Diameters
- Single Spindle
- Dual Spindle Option
- Unwind Option
- Rewind Option
- Paper Interleaf Spindle Option
- Traverse Mechanism for Rewinding

BENEFITS:

- Smooth Payout or Rewind of your Materials on Spools
- Heavy Duty, Rugged Frame Construction for long, trouble free operation
- Easy Loading of Spools
- Highest Quality Components
- (3) Year Warranty
- Versatile machine that handles most Uncoiling or Rewinding applications on Spools

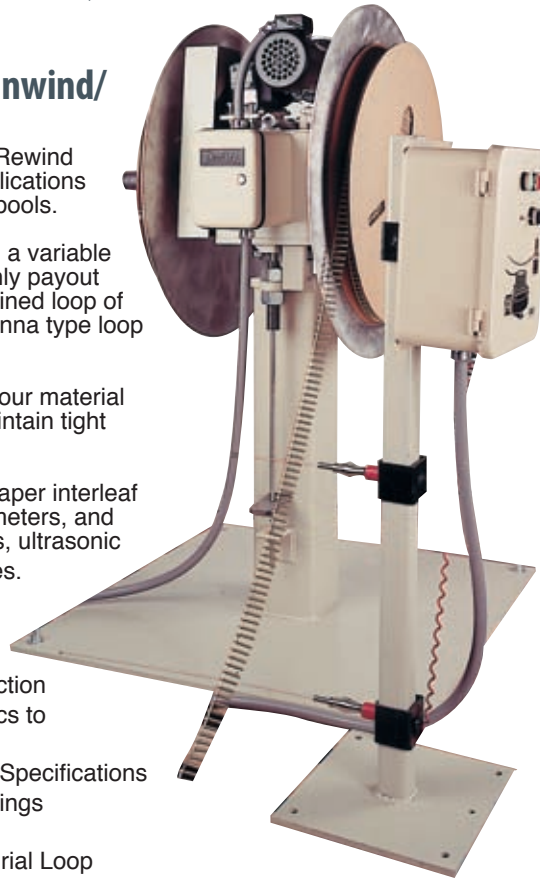

VS-DMD-SS

Dual Spindle

See Pages 34-35.

VARIABLE SPEED MOTORIZED

Model	Core Diameter	Max. Width	Spindle RPM	Motor Capacity
VS DMD	Specify	3"	0-80	1/4 HP 110V-1PH
VS DMD-1	Specify	6"	0-80	1/4 HP 110V-1PH
VS DMD-2	Specify	10"	0-80	1/4 HP 110V-1PH
VS DMD-3	Specify	16"	0-80	1/4 HP 110V-1PH
VS DMD-4	Specify	24"	0-80	1/4 HP 110V-1PH

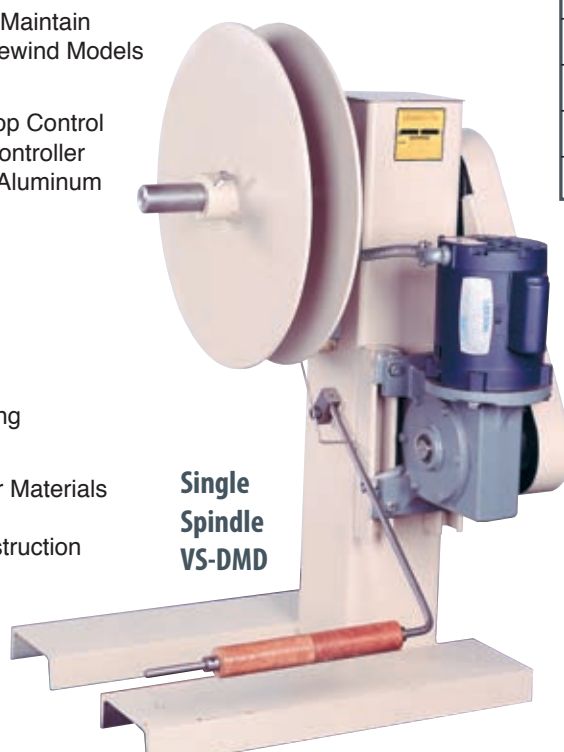

Single Spindle VS-DMD

UNMOTORIZED

Model	Core Diameter	Max. Width	Weight Capacity	Brake
DD	Specify	3"	200 lbs. 500 lbs. 1000 lbs.	Standard Drag
DD-1	Specify	6"	200 lbs. 500 lbs. 1000 lbs.	Standard Drag
DD-2	Specify	10"	200 lbs. 500 lbs. 1000 lbs.	Standard Drag
DD-3	Specify	16"	200 lbs. 500 lbs. 1000 lbs.	Standard Drag
DD-4	Specify	24"	200 lbs. 500 lbs. 1000 lbs.	Standard Drag

See Pages 34-35 for Double Spindle Decoilers and Rewind Machines.

Adjustable Core Unwind / Rewind Reels

Stock Reels With Keeper Arms

Unmotorized Models

Model DSC with Keeper Arms (unmotorized)

All Durant Decoilers are available in non-motorized and variable speed motorized models. These rugged constructed machines have (6) quick adjust coil keeper arms that are easily located on heavy rods for narrow or wide coils. (2) Heavy Duty Bearings insure long term trouble free operation. The variable speed motorized models include a variable speed controller and variable speed dancer type loop control as standard equipment.

UNMOTORIZED						
Model	Maximum Width	Maximum OD	Core Diameter	Weight Capacity	Motor	Brake
D50-U	6"	44"	6-24"	50 lbs.	None	Standard
D100-U	6"	44"	6-24"	100 lbs.	None	Standard
D250-U	6"	44"	6-24"	250 lbs.	None	Standard
DSC-0	8"	44"	6-24"	400 lbs.	None	Standard
DSC-1	10"	44"	6-24"	600 lbs.	None	Standard
DSC-2	13"	48"	8-24"	1200 lbs.	None	Standard
DSC-3	18"	48"	8-24"	600 lbs.	None	Standard

Motorized Models with Keeper Arms

Model VS-DMSC with Keeper Arms

These models offer all the advantages of our unmotorized DSC Models -- self centering, ball bearing construction, and easy to operate arms located on heavy rods for either wide or narrow coils. In addition, the motorization on these models make it possible to set up for just about any range of coils you're likely to require.

VARI SPEED MOTORIZED						
Model	Max. Width	Max. OD	Core Diameter	Weight Capacity	Motor	Spindle RPM
VS-D50-M	6"	44"	6-24"	50 lbs.	1/3 HP, 110V	0-25
VS-D100-M	6"	44"	6-24"	100 lbs.	1/3 HP, 110V	0-25
VS-D250-M	6"	44"	6-24"	250 lbs.	1/3 HP, 110V	0-25
VS-DMSC-0	8"	44"	6-24"	400 lbs.	1/3 HP, 110V	0-25
VS-DMSC-1	10"	44"	6-24"	600 lbs.	1/3 HP, 110V	0-25
VS-DMSC-2	13"	48"	8-24"	1200 lbs.	1/3 HP, 110V	0-25
VS-DMSC-3	18"	48"	8-24"	600 lbs.	1/3 HP, 110V	0-25

FEATURES:

- Heavy Duty Steel Frame Construction
- Rugged Cast: Quick Adjust Keeper Arms
- 1-1/2" Diameter Main Spindle Shaft
- (2) Heavy Duty Main Spindle Bearings
- Variable Speed Dancer Type Material Loop Control
- Heavy Duty Gear Reducer

OPTIONS:

- Variable Speed Antenna Type Loop Control
- A-1 Sonic Type No Touch Loop Control
- Coil Discs in place of Keeper Arms 36", 48", 60" Diameter
- Rewind Option
- Double Spindle Option

BENEFITS:

- Smooth Payout or rewinding of your materials
- Heavy Duty, Rugged Frame Construction for long trouble free operation
- Easy Loading of Coils
- Highest Quality Components
- (3) Year Warranty
- Versatile machine that handles most Press, Roll Forming, Wire Forming, Uncoiling and Rewinding applications

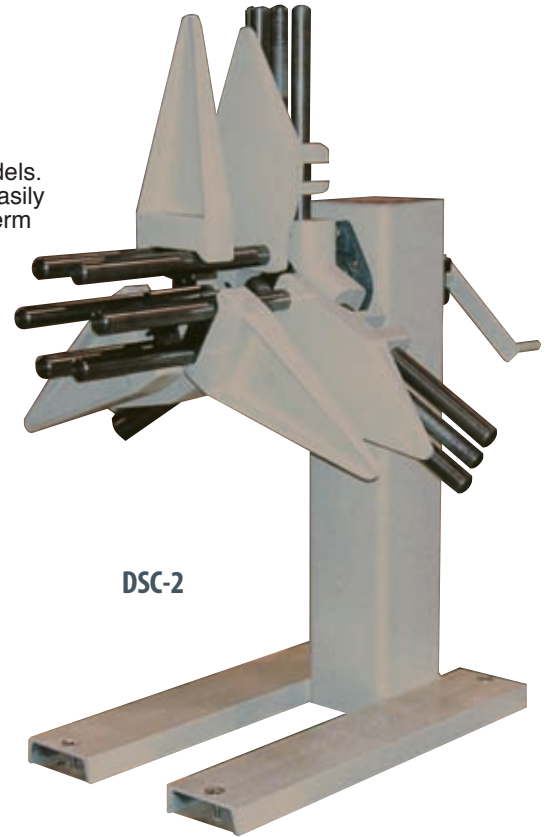

DSC-2

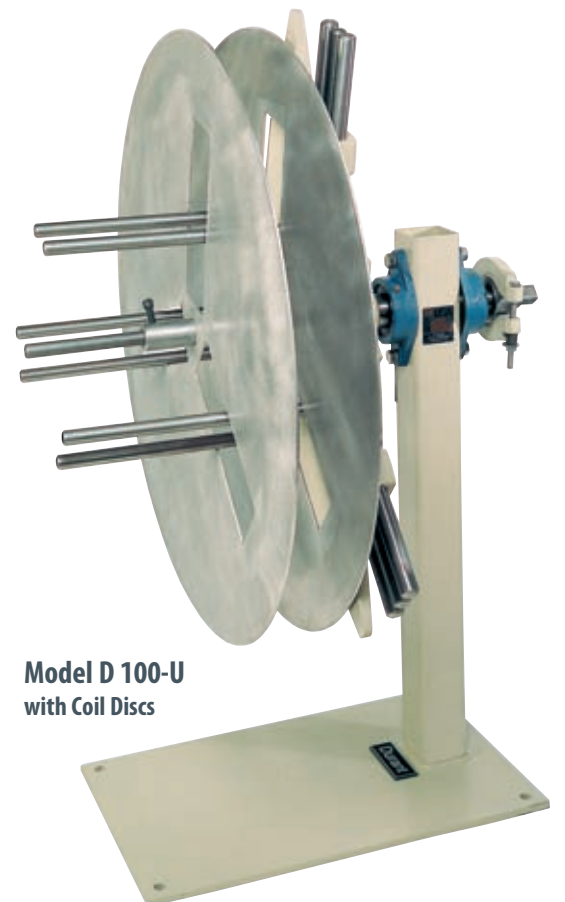

Model D 100-U
with Coil Discs

Adjustable Core Unwind / Rewind Reels

Motorized Models with Coil Discs

All Durant Decoilers are available in non-motorized and variable speed motorized models. These rugged constructed machines have (6) quick adjust coil keeper arms that are easily located on heavy rods for narrow or wide coils. (2) Heavy Duty Bearings insure long term trouble free operation.

The variable speed motorized models include a variable speed controller and variable speed dancer type loop control as standard equipment.

FEATURES:

- Heavy Duty Steel Frame Construction
- Rugged Cast: Quick Adjust Keeper Arms
- 1-1/2" Diameter Main Spindle Shaft
- (2) Heavy Duty Main Spindle Bearings
- Variable Speed Dancer Type Material Loop Control
- Heavy Duty Gear Reducer

OPTIONS:

- Variable Speed Antenna Type Loop Control
- A-1 Sonic Type No Touch Loop Control
- Coil Discs in place of Keeper Arms 36", 48", 60" Diameter
- Rewind Option
- Double Spindle Option

BENEFITS:

- Smooth Payout or rewinding of your materials
- Heavy Duty, Rugged Frame Construction for long trouble free operation
- Easy Loading of Coils
- Highest Quality Components
- (3) Year Warranty
- Versatile machine that handles most Press, Roll Forming, Wire Forming, Uncoiling and Rewinding applications



VS-DMSC-2-CD-48

Need Stock Reels?
Durant Has The Largest Selection In The Metal Stamping Industry!

Model VS-DMSC-CD with Coil Discs Variable Speed Motorized

Durant's very popular D Series stock reels are now equipped, as a standard item, with coil discs in place of keeper arms. All coil discs are 1/8" thick, and are available in 30", 36", 48", 60" outside diameter plates.

These heavily constructed stock reels, with coil discs and vari-speed dancer loop control, offer total versatility and trouble free performance.

VARI SPEED MOTORIZED					
Model	Max. Width	Max. OD	Core Dia.	Weight Capacity	Motor
VS-D50-M-CD-24	6"	24"	6-24"	50 lbs.	1/3 HP, 110 V
VS-D100-M-CD-35	6"	35"	6-24"	100 lbs.	1/3 HP, 110 V
VS-D250-M-CD-35	6"	35"	6-24"	250 lbs.	1/3 HP, 110 V
VS-DMSC-0-CD-48	8"	48"	6-24"	400 lbs.	1/3 HP, 110 V
VS-DMSC-1-CD-48	10"	48"	6-24"	600 lbs.	1/3 HP, 110 V
VS-DMSC-2-CD-48	13"	48"	8-24"	1200 lbs.	1/3 HP, 110 V
VS-DMSC-3-CD-48	18"	48"	8-24"	600 lbs.	1/3 HP, 110 V

Also available with double spindle. See pages 34-35.

OPTIONS:

- Rewind Option
- 4" I.D. Coils

Adjustable Core Unwind / Rewind Reels

When pay out has to pay off in a big way...

Model MD-1500 Unmotorized

When it comes to the 1500 pound stock reel class, the Durant MD-1500 Series is in a class by itself. Constructed of durable, heavy walled steel tubing throughout, these reels offer 1500 pound capacity. They are equipped with six rugged coil arms which easily adjust on heavy rods, and a drag brake, which comes standard on all models, eliminating material over travel.



MD-1512-U

FEATURES:

- Heavy Duty Steel Frame Construction
- Rugged Cast: Quick Adjust Keeper Arms
- 3" Diameter Main Spindle Shaft
- (2) Heavy Duty Main Spindle Bearings
- Variable Speed Dancer Type Material Loop Control
- Heavy Duty Gear Reducer

OPTIONS:

- Variable Speed Antenna Type Loop Control
- A-1 Sonic Type No Touch Loop Control
- Coil Discs in place of Keeper Arms 36", 48", 60" Diameter
- Rewind Option
- Double Spindle Option
- Hydraulic Hold Down Arm for Spring /Expanding Material

BENEFITS:

- Smooth Payout or rewinding of your materials
- Heavy Duty, Rugged Frame Construction for long trouble free operation
- Easy Loading of Coils
- Highest Quality Components
- (3) Year Warranty
- Versatile machine that handles most Press, Roll Forming, Wire Forming, Uncoiling and Rewinding applications

UNMOTORIZED					
Model	Max. Width	I.D.	Max. O.D.	Brake	Weight Capacity
MD-1512-U	12"	15-20"	54"	Std.	1500 lbs.
MD-1516-U	16"	15-20"	54"	Std.	1500 lbs.
MD-1524-U	24"	15-20"	54"	Std.	1500 lbs.
MD-1530-U	30"	15-20"	54"	Std.	1500 lbs.

Also available with double spindle. See pages 34-35.

OPTION:

- Back Plate 60" O.D. Coil
- Air or Electric Brake

Model MD-1500 Variable Speed Motorized

If you are looking to get long service with minimum maintenance, you are looking for a stock reel with self centering, easy loading, and loop control as standard features. That is exactly what you get with this series of stock reels from Durant. The standard motorization is 220/440 60C 3 phase with a 3/4 HP motor. To make sure there is a free loop of material in front of the feed at all times, these reels are equipped with a special loop control feature.

VARIABLE SPEED MOTORIZED					
Model Variable Speed	Max. Width	I.D.	Max. O.D.	Motor	Weight Capacity
VS-MD-1512-M	12"	15-20"	54"	3/4 HP, 220/440 Volt	1500 lbs.
VS-MD-1516-M	16"	15-20"	54"	3/4 HP, 220/440 Volt	1500 lbs.
VS-MD-1524-M	24"	15-20"	54"	3/4 HP, 220/440 Volt	1500 lbs.
VS-MD-1530-M	30"	15-20"	54"	3/4 HP, 220/440 Volt	1500 lbs.

"VS" - Variable Speed DC Drive
Also available with double spindle. See pages 34-35.

OPTION: • Back Plate 60" O.D. Coil



Adjustable Core Unwind / Rewind Reels

...Call on Durant.

Model MD-2000 Unmotorized

When it comes to the 1,500 to 2,000 pound stock reel class, the Durant MD-2000 Series is in a class by itself. Constructed of durable, heavy walled steel tubing throughout, these reels offer a full 2,000 pound capacity. They are equipped with six rugged coil arms which easily adjust on heavy rods. A drag brake, which comes standard on all models, eliminates material over travel.

UNMOTORIZED					
Model	Width	I.D.	Max. O.D.	Brake	Weight Capacity
MD-2012-U	12"	15-20"	54"	STD	2000 lbs.
MD-2016-U	16"	15-20"	54"	STD	2000 lbs.
MD-2024-U	24"	15-20"	54"	STD	2000 lbs.
MD-2030-U	30"	15-20"	54"	STD	2000 lbs.



FEATURES:

- Heavy Duty Steel Frame Construction
- Rugged Cast: Quick Adjust Keeper Arms
- 3" Diameter Main Spindle Shaft
- (2) Heavy Duty Main Spindle Bearings
- Variable Speed Dancer Type Material Loop Control
- Heavy Duty Gear Reducer

OPTIONS:

- Variable Speed Antenna Type Loop Control
- A-1 Sonic Type No Touch Loop Control
- Coil Discs in place of Keeper Arms 36", 48", 60" Diameter
- Rewind Option
- Double Spindle Option
- Hydraulic Hold Down Arm for Spring /Expanding Material

BENEFITS:

- Smooth Payout or rewinding of your materials
- Heavy Duty, Rugged Frame Construction for long trouble free operation
- Easy Loading of Coils
- Highest Quality Components
- (3) Year Warranty
- Versatile machine that handles most Press, Roll Forming, Wire Forming, Uncoiling and Rewinding applications

Model MD-2000 Variable Speed Motorized

If you are looking to get long service with minimum maintenance, you are looking for a stock reel with self centering, easy loading, and loop control as standard features. That is exactly what you get with this series of stock reels from Durant. The standard motorization is 220/440 60C 3 phase with a 3/4 HP motor. Combined with a gear reducer it gives you 0-19 RPM standard spindle speed which provides a feed out of 72 feet per minute. To make sure there is a free loop of material in front of the feed at all times, these reels are equipped with a special loop control feature.

VARIABLE SPEED MOTORIZED					
Model Variable Speed	Width	I.D.	Max. O.D.	Motor	Weight Capacity
VS-MD-2012-M	12"	15-20"	54"	3/4 HP, 220/440 Volt	2000 lbs.
VS-MD-2016-M	16"	15-20"	54"	3/4 HP, 220/440 Volt	2000 lbs.
VS-MD-2024-M	24"	15-20"	54"	3/4 HP, 220/440 Volt	2000 lbs.
VS-MD-2030-M	30"	15-20"	54"	3/4 HP, 220/440 Volt	2000 lbs.

Need Stock Reels?

Durant Has The Largest Selection In The Metal Stamping Industry!



Adjustable Core Unwind / Rewind Reels

When pay out has to pay off in a big way...Call on Durant.

All Durant Decoilers are available in non-motorized and variable speed motorized models. These rugged constructed machines have (6) quick adjust coil keeper arms that are easily located on heavy rods for narrow or wide coils. (2) Heavy Duty Bearings insure long term trouble free operation.

The variable speed motorized models include a variable speed controller and variable speed dancer type loop control as standard equipment.

Model MD-250, MD-300, MD-400 Unmotorized

UNMOTORIZED					
Model	Max. Width	I.D.	Max. O.D.	Brake	Wt. Capacity
MD-251-U	16"	15-20"	54"-60"	STD	2500 lbs.
MD-252-U	24"	15-20"	54"-60"	STD	2500 lbs.
MD-253-U	32"	15-20"	54"-60"	STD	2500 lbs.
MD-254-U	36"	15-20"	54"-60"	STD	2500 lbs.
MD-301-U	16"	15-20"	54"-60"	STD	3000 lbs.
MD-302-U	24"	15-20"	54"-60"	STD	3000 lbs.
MD-303-U	32"	15-20"	54"-60"	STD	3000 lbs.
MD-304-U	36"	15-20"	54"-60"	STD	3000 lbs.
MD-401-U	16"	15-20"	54"-60"	STD	4000 lbs.
MD-402-U	24"	15-20"	54"-60"	STD	4000 lbs.
MD-403-U	32"	15-20"	54"-60"	STD	4000 lbs.
MD-404-U	36"	15-20"	54"-60"	STD	4000 lbs.

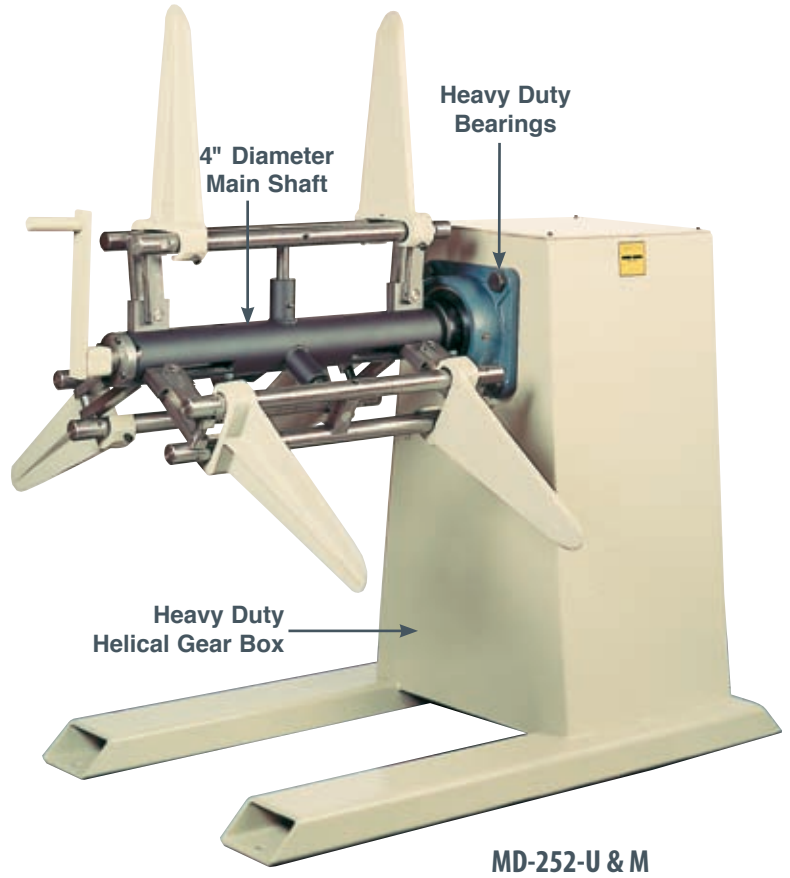

FEATURES:

- Heavy Duty Steel Frame Construction
- Rugged Cast: Quick Adjust Keeper Arms
- 4" Diameter Main Spindle Shaft
- (2) Heavy Duty Main Spindle Bearings
- Variable Speed Dancer Type Material Loop Control
- Heavy Duty Gear Reducer

OPTIONS:

- Variable Speed Antenna Type Loop Control
- A-1 Sonic Type No Touch Loop Control
- Coil Discs in place of Keeper Arms 36", 48", 60" Diameter
- Rewind Option
- Double Spindle Option
- Hydraulic Core Expansion
- Hydraulic Hold Down Arm for Spring /Expanding Material

BENEFITS:

- Smooth Payout or rewinding of your materials
- Heavy Duty, Rugged Frame Construction for long trouble free operation
- Easy Loading of Coils
- Highest Quality Components
- (3) Year Warranty
- Versatile machine that handles most Press, Roll Forming, Wire Forming, Uncoiling and Rewinding applications

Model MD-250, MD-300, MD-400 Variable Speed Motorized

VARIABLE SPEED MOTORIZED					
Variable Speed	Max. Width	I.D.	Max. O.D.	Motor	Wt. Capacity
VS-MD-251-M	16"	15-20"	54"-60"	1 1/2 HP	2500 lbs.
VS-MD-252-M	24"	15-20"	54"-60"	1 1/2 HP	2500 lbs.
VS-MD-253-M	32"	15-20"	54"-60"	1 1/2 HP	2500 lbs.
VS-MD-254-M	36"	15-20"	54"-60"	1 1/2 HP	2500 lbs.
VS-MD-301-M	16"	15-20"	54"-60"	2 HP	3000 lbs.
VS-MD-302-M	24"	15-20"	54"-60"	2 HP	3000 lbs.
VS-MD-303-M	32"	15-20"	54"-60"	2 HP	3000 lbs.
VS-MD-304-M	36"	15-20"	54"-60"	2 HP	3000 lbs.
VS-MD-401-M	16"	15-20"	54"-60"	2 HP	4000 lbs.
VS-MD-402-M	24"	15-20"	54"-60"	2 HP	4000 lbs.
VS-MD-403-M	32"	15-20"	54"-60"	2 HP	4000 lbs.
VS-MD-404-M	36"	15-20"	54"-60"	2 HP	4000 lbs.



Heavy Duty Unwind / Rewind Reels

MD-500, MD-600 Unmotorized

All Durant Decoilers are available in non-motorized and variable speed motorized models. These rugged constructed machines have (6) quick adjust coil keeper arms that are easily located on heavy rods for narrow or wide coils. (2) Heavy Duty Bearings insure long term trouble free operation.

UNMOTORIZED					
Model	Max. Width	I.D.	Max. O.D.	Brake	Wt. Capacity
MD-501-U	12"	15-20"	54-60"	STD	5000 lbs.
MD-502-U	24"	15-20"	54-60"	STD	5000 lbs.
MD-503-U	32"	15-20"	54-60"	STD	5000 lbs.
MD-504-U	36"	15-20"	54-60"	STD	5000 lbs.
MD-505-U	48"	15-20"	54-60"	STD	3000 lbs.
MD-601-U	12"	15-20"	54-60"	STD	6000 lbs.
MD-602-U	24"	15-20"	54-60"	STD	6000 lbs.
MD-603-U	32"	15-20"	54-60"	STD	6000 lbs.
MD-604-U	36"	15-20"	54-60"	STD	6000 lbs.
MD-605-U	48"	15-20"	54-60"	STD	3000 lbs.

FEATURES:

- Heavy Duty Steel Frame Construction
- Rugged Cast: Quick Adjust Keeper Arms
- 4" Diameter Main Spindle Shaft
- (2) Heavy Duty Main Spindle Bearings
- Variable Speed Dancer Type Material Loop Control
- Heavy Duty Gear Reducer

OPTIONS:

- Variable Speed Antenna Type Loop Control
- A-1 Sonic Type No Touch Loop Control
- Rewind Option
- Double Spindle Option
- Hydraulic Hold Down Arm for Spring /Expanding Material

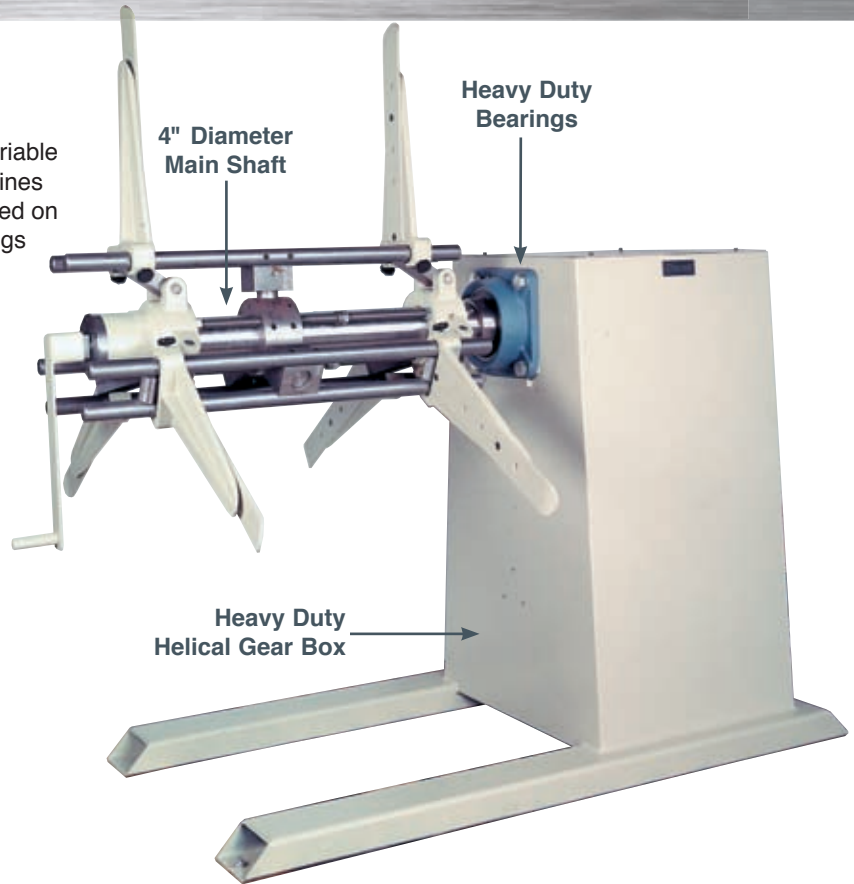

VS-MD-603-M
with BACK PLATE

*Model MD-603-M Stock Reel with Back Plate and Coil I.D. Segments.
These Optional features are available for all Durant Stock Reels.*

BENEFITS:

- Smooth Payout or rewinding of your materials
- Heavy Duty, Rugged Frame Construction for long trouble free operation
- Easy Loading of Coils
- Highest Quality Components
- (3) Year Warranty
- Versatile machine that handles most Press, Roll Forming, Wire Forming, Uncoiling and Rewinding applications

MD-500, MD-600 Variable Speed Motorized

The variable speed motorized models include a variable speed controller and variable speed dancer type loop control as standard equipment.

VARIABLE SPEED MOTORIZED				
Variable Speed	Max. Width	I.D.	Max. O.D.	Wt. Capacity
VS-MD-501-M	12"	15-20"	54-60"	5000 lbs.
VS-MD-502-M	24"	15-20"	54-60"	5000 lbs.
VS-MD-503-M	32"	15-20"	54-60"	5000 lbs.
VS-MD-504-M	36"	15-20"	54-60"	5000 lbs.
VS-MD-505-M	48"	15-20"	54-60"	3000 lbs.
VS-MD-601-M	12"	15-20"	54-60"	6000 lbs.
VS-MD-602-M	24"	15-20"	54-60"	6000 lbs.
VS-MD-603-M	32"	15-20"	54-60"	6000 lbs.
VS-MD-604-M	36"	15-20"	54-60"	6000 lbs.
VS-MD-605-M	48"	15-20"	54-60"	3000 lbs.

Heavy Duty Decoilers

Heavy Duty Uncoiling . . .Call On Durant!

Durant HD Series Decoilers

Durant HD Series Decoilers are available in both non-motorized and variable speed motorized models. The variable speed motorized models include a variable speed controller and variable speed Dancer Type Loop Control as standard equipment. All rotating parts are mounted on heavy duty bearings for maximum efficiency with a minimum cost of operation. An important feature of all Durant HD Decoilers is the use of wedges for expanding the arbor. Wedge type expansion insures smooth and easy loading whether the operator expands the mandrel mechanically or hydraulically.

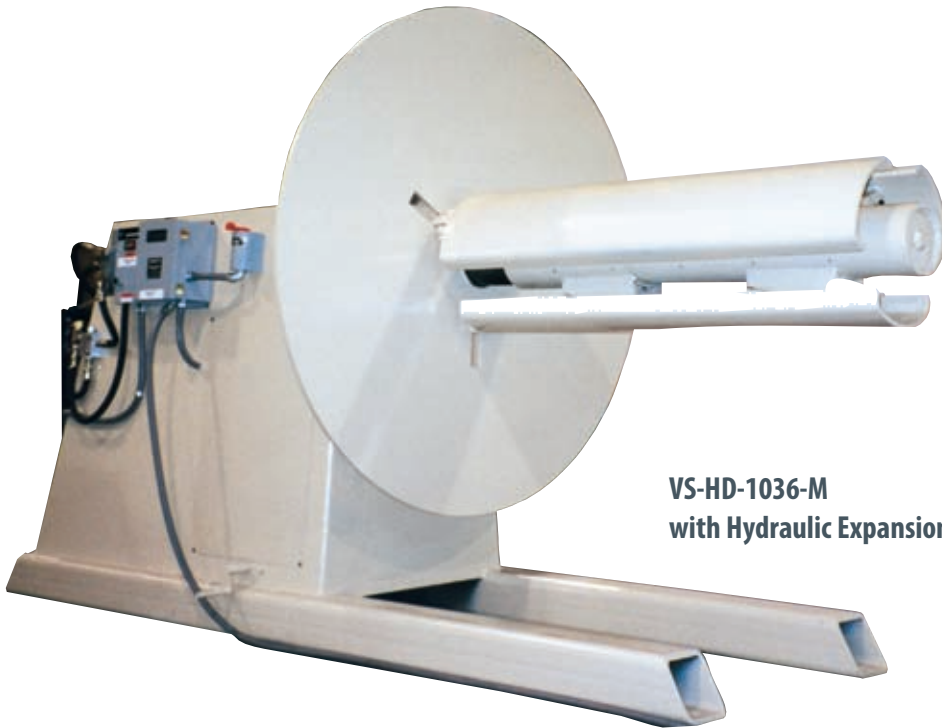

**VS-HD-1036-M
with Hydraulic Expansion**

FEATURES:

- Heavy Duty Steel Frame Construction
- Rugged Quick Adjust Keeper Arms
- 6" Diameter Main Spindle Shaft
- (2) Heavy Duty Main Spindle Bearings
- Variable Speed Dancer Type Material Loop Control
- Heavy Duty Gear Reducer

OPTIONS:

- Variable Speed Antenna Type Loop Control
- A-1 Sonic Type No Touch Loop Control
- Rewind Option
- Hydraulic Core Expansion
- Hydraulic Hold Down Arm for Spring/Expanding Material

BENEFITS:

- Smooth Payout or rewinding of your materials
- Heavy Duty, Rugged Frame Construction for long trouble free operation
- Easy Loading of Coils
- Highest Quality Components
- (3) Year Warranty
- Versatile machine that handles most Press, Roll Forming, Wire Forming, Uncoiling, and Rewinding applications

UNMOTORIZED

Model	Max. Width	I.D.	Max. O.D.	Brake	Wt. Capacity
HD 624-U	24"	15 1/2 - 20	60"	STD	6000 lbs.
HD 630-U	30"	15 1/2 - 20	60"	STD	6000 lbs.
HD 636-U	36"	15 1/2 - 20	60"	STD	6000 lbs.
HD 648-U	48"	15 1/2 - 20	60"	STD	6000 lbs.
HD 824-U	24"	15 1/2 - 20	60"	STD	8000 lbs.
HD 830-U	30"	15 1/2 - 20	60"	STD	8000 lbs.
HD 836-U	36"	15 1/2 - 20	60"	STD	8000 lbs.
HD 848-U	48"	15 1/2 - 20	60"	STD	8000 lbs.
HD 860-U	60"	15 1/2 - 20	60"	STD	8000 lbs.
HD 1024-U	24"	15 1/2 - 20	60"	STD	10,000 lbs.
HD 1030-U	30"	15 1/2 - 20	60"	STD	10,000 lbs.
HD 1036-U	36"	15 1/2 - 20	60"	STD	10,000 lbs.
HD 1048-U	48"	15 1/2 - 20	60"	STD	10,000 lbs.
HD 1060-U	60"	15 1/2 - 20	60"	STD	10,000 lbs.
HD 1224-U	24"	18-23"	60"	STD	12,000 lbs.
HD 1230-U	30"	18-23"	60"	STD	12,000 lbs.
HD 1236-U	36"	18-23"	60"	STD	12,000 lbs.
HD 1248-U	48"	18-23"	60"	STD	12,000 lbs.
HD 1260-U	60"	18-23"	60"	STD	12,000 lbs.
HD 1524-U	24"	18-23"	60"	STD	15,000 lbs.
HD 1530-U	30"	18-23"	60"	STD	15,000 lbs.
HD 1536-U	36"	18-23"	60"	STD	15,000 lbs.
HD 1548-U	48"	18-23"	60"	STD	15,000 lbs.
HD 1560-U	60"	18-23"	60"	STD	15,000 lbs.

VARIABLE SPEED MOTORIZED

Model	Max. Width	I.D.	Max. O.D.	Motor	Wt. Capacity
VS 624-M	24"	15 1/2 - 20	60"	3 HP	6000 lbs.
VS 630-M	30"	15 1/2 - 20	60"	3 HP	6000 lbs.
VS 636-M	36"	15 1/2 - 20	60"	3 HP	6000 lbs.
VS 648-M	48"	15 1/2 - 20	60"	3 HP	6000 lbs.
VS 824-M	24"	15 1/2 - 20	60"	5 HP	8000 lbs.
VS 830-M	30"	15 1/2 - 20	60"	5 HP	8000 lbs.
VS 836-M	36"	15 1/2 - 20	60"	5 HP	8000 lbs.
VS 848-M	48"	15 1/2 - 20	60"	5 HP	8000 lbs.
VS 860-M	60"	15 1/2 - 20	60"	5 HP	8000 lbs.
VS 1024-M	24"	15 1/2 - 20	60"	5 HP	10,000 lbs.
VS 1030-M	30"	15 1/2 - 20	60"	5 HP	10,000 lbs.
VS 1036-M	36"	15 1/2 - 20	60"	5 HP	10,000 lbs.
VS 1048-M	48"	15 1/2 - 20	60"	5 HP	10,000 lbs.
VS 1060-M	60"	15 1/2 - 20	60"	5 HP	10,000 lbs.
VS 1224-M	24"	18-23"	60"	5 HP	12,000 lbs.
VS 1230-M	30"	18-23"	60"	5 HP	12,000 lbs.
VS 1236-M	36"	18-23"	60"	5 HP	12,000 lbs.
VS 1248-M	48"	18-23"	60"	5 HP	12,000 lbs.
VS 1260-M	60"	18-23"	60"	5 HP	12,000 lbs.
VS 1524-M	24"	18-23"	60"	5 HP	15,000 lbs.
VS 1530-M	30"	18-23"	60"	5 HP	15,000 lbs.
VS 1536-M	36"	18-23"	60"	5 HP	15,000 lbs.
VS 1548-M	48"	18-23"	60"	5 HP	15,000 lbs.
VS 1560-M	60"	18-23"	60"	5 HP	15,000 lbs.

Heavy Duty Decoilers



HD636-U



VS-HD 1030-M
with hold down arm



Double Spindle Decoilers

Increase Factory Productivity . . .

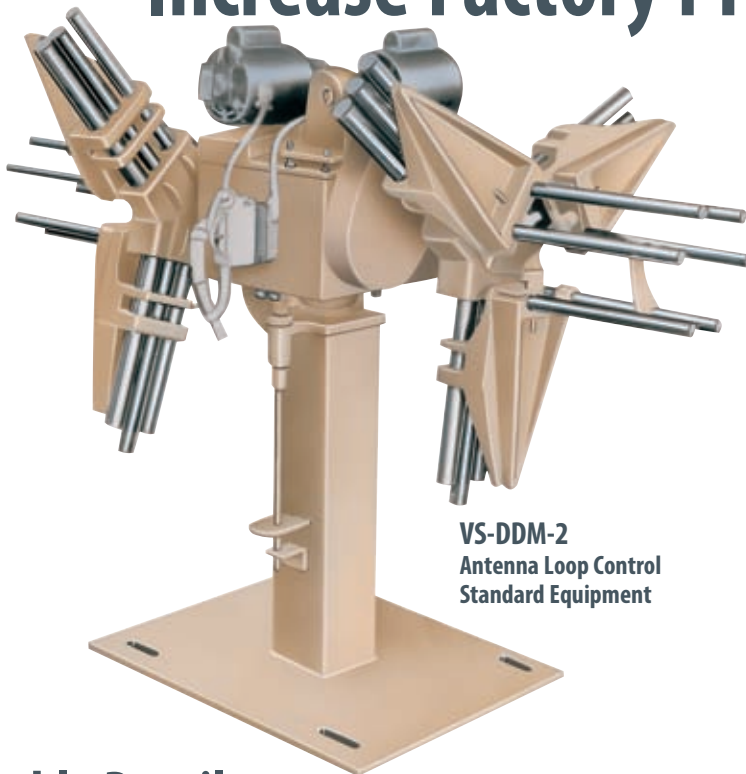

VS-DDM-2
Antenna Loop Control
Standard Equipment

VARIABLE SPEED MOTORIZED					
Model	Max. Width	I.D.	Max. O.D.	Motor	Wt. Capacity
VS-DD100-M	6"	6-24"	44"	1/3 HP	100 lbs.
VS-DD250-M	6"	6-24"	44"	1/3 HP	250 lbs.
VS-DDM-0	8"	6-24"	44"	1/3 HP	400 lbs.
VS-DDM-1	10"	6-24"	44"	1/3 HP	600 lbs.
VS-DDM-2	13"	8-24"	48"	1/3 HP	1,200 lbs.
VS-MDD-1512-M	12"	15-20"	54"	3/4 HP	1,500 lbs.
VS-MDD-1516-M	16"	15-20"	54"	3/4 HP	1,500 lbs.
VS-MDD-1524-M	24"	15-20"	54"	3/4 HP	1,500 lbs.
VS-MDD-1530-M	30"	15-20"	54"	3/4 HP	1,500 lbs.
VS-MDD-2012-M	12"	15-20"	54"	1 HP	2,000 lbs.
VS-MDD-2016-M	16"	15-20"	54"	1 HP	2,000 lbs.
VS-MDD-2024-M	24"	15-20"	54"	1 HP	2,000 lbs.
VS-MDD-2030-M	30"	15-20"	54"	1 HP	2,000 lbs.
VS-MDD-3012-M	12"	15-20"	60"	1.5 HP	3,000 lbs.
VS-MDD-3016-M	16"	15-20"	60"	1.5 HP	3,000 lbs.
VS-MDD-3024-M	24"	15-20"	60"	1.5 HP	3,000 lbs.
VS-MDD-3032-M	32"	15-20"	60"	1.5 HP	3,000 lbs.
VS-MDD-3036-M	36"	15-20"	60"	1.5 HP	3,000 lbs.
VS-MDD-4012-M	12"	15-20"	60"	2 HP	4,000 lbs.
VS-MDD-4016-M	16"	15-20"	60"	2 HP	4,000 lbs.
VS-MDD-4024-M	24"	15-20"	60"	2 HP	4,000 lbs.
VS-MDD-4032-M	32"	15-20"	60"	2 HP	4,000 lbs.
VS-MDD-4036-M	36"	15-20"	60"	2 HP	4,000 lbs.

Double Decoilers

All Models of Durant Decoilers are available in both Single Spindle and Double Spindle versions. The Double Spindle models allows you to increase Manufacturing Productivity. When one side of the machine is uncoiling material, the operator can load the other side. A foot release pedal keeps the spindle in position. It can be turned 180 degrees when fully loaded with the foot pedal. Variable Speed Dancer Type Material Loop Controllers are standard equipment on all Motorized models. Increase your Productivity! Consider Double Spindle Decoilers with adjustable expanding cores for bulk coils or with fixed solid spindles for materials on spools. Durant manufactures all models in both Non-Motorized "Pull Off" or Variable Speed Motorized versions.

FEATURES:

- Double Rotating Spindles
- Heavy Duty Steel Frame Construction
- (2) Heavy Duty Main Spindle Bearings
- Heavy Duty Gear Reducer
- Variable Speed Dancer Type Material Loop Control

OPTIONS:

- A-1 Sonic Type No Touch Loop Control
- Coil Discs in place of Keeper Arms 36", 48", 60" Diameter
- Rewind Option

BENEFITS:

- Increased Productivity with Double Spindle models. Operator loads one spindle while the other spindle uncoils the material
- Smooth Payout or rewinding of your materials
- Heavy Duty, Rugged Frame Construction for long trouble free operation
- Easy Loading of Coils
- Highest Quality Components
- (3) Year Warranty
- Versatile machine that handles most Press, Roll Forming, Wire Forming, Uncoiling or Rewinding applications

NON-MOTORIZED					
Model	Max. Width	I.D.	Max. O.D.	Brake	Wt. Capacity
DD100-U	6"	6-24"	44"	HD	100 lbs.
DD250-U	6"	6-24"	44"	HD	250 lbs.
DDSC-0	8"	6-24"	44"	HD	400 lbs.
DDSC-1	10"	6-24"	44"	HD	600 lbs.
DDSC-2	13"	8-24"	48"	HD	1,200 lbs.
MDD-1512-U	12"	15-20"	54"	HD	1,500 lbs.
MDD-1516-U	16"	15-20"	54"	HD	1,500 lbs.
MDD-1524-U	24"	15-20"	54"	HD	1,500 lbs.
MDD-1530-U	30"	15-20"	54"	HD	1,500 lbs.
MDD-2012-U	12"	15-20"	54"	HD	2,000 lbs.
MDD-2016-U	16"	15-20"	54"	HD	2,000 lbs.
MDD-2024-U	24"	15-20"	54"	HD	2,000 lbs.
MDD-2030-U	30"	15-20"	54"	HD	2,000 lbs.
MDD-3012-U	12"	15-20"	60"	HD	3,000 lbs.
MDD-3016-U	16"	15-20"	60"	HD	3,000 lbs.
MDD-3024-U	24"	15-20"	60"	HD	3,000 lbs.
MDD-3032-U	32"	15-20"	60"	HD	3,000 lbs.
MDD-3036-U	36"	15-20"	60"	HD	3,000 lbs.
MDD-4012-U	12"	15-20"	60"	HD	4,000 lbs.
MDD-4016-U	16"	15-20"	60"	HD	4,000 lbs.
MDD-4024-U	24"	15-20"	60"	HD	4,000 lbs.
MDD-4032-U	32"	15-20"	60"	HD	4,000 lbs.
MDD-4036-U	36"	15-20"	60"	HD	4,000 lbs.

IMPORTANT NOTE: Either solid core or adjustable expanding core available. Call Durant!



Double Spindle Decoilers

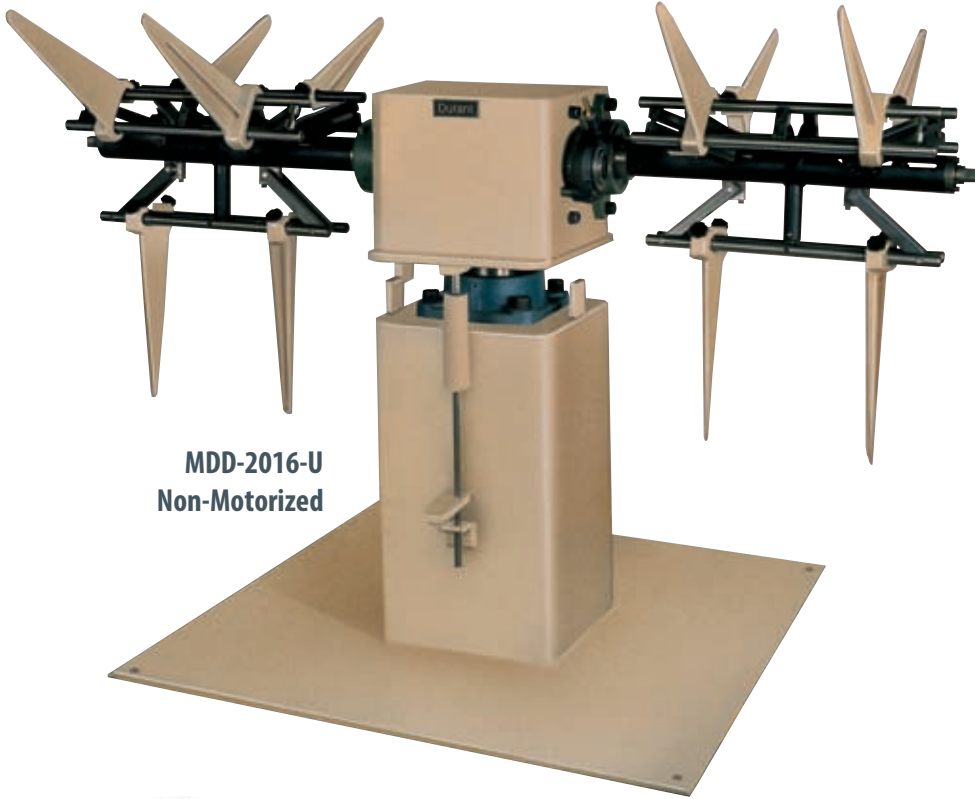

MDD-2016-U
Non-Motorized



VS-DMD-SS
VS-DMD Double
with rotating
side by side
solid
spindles

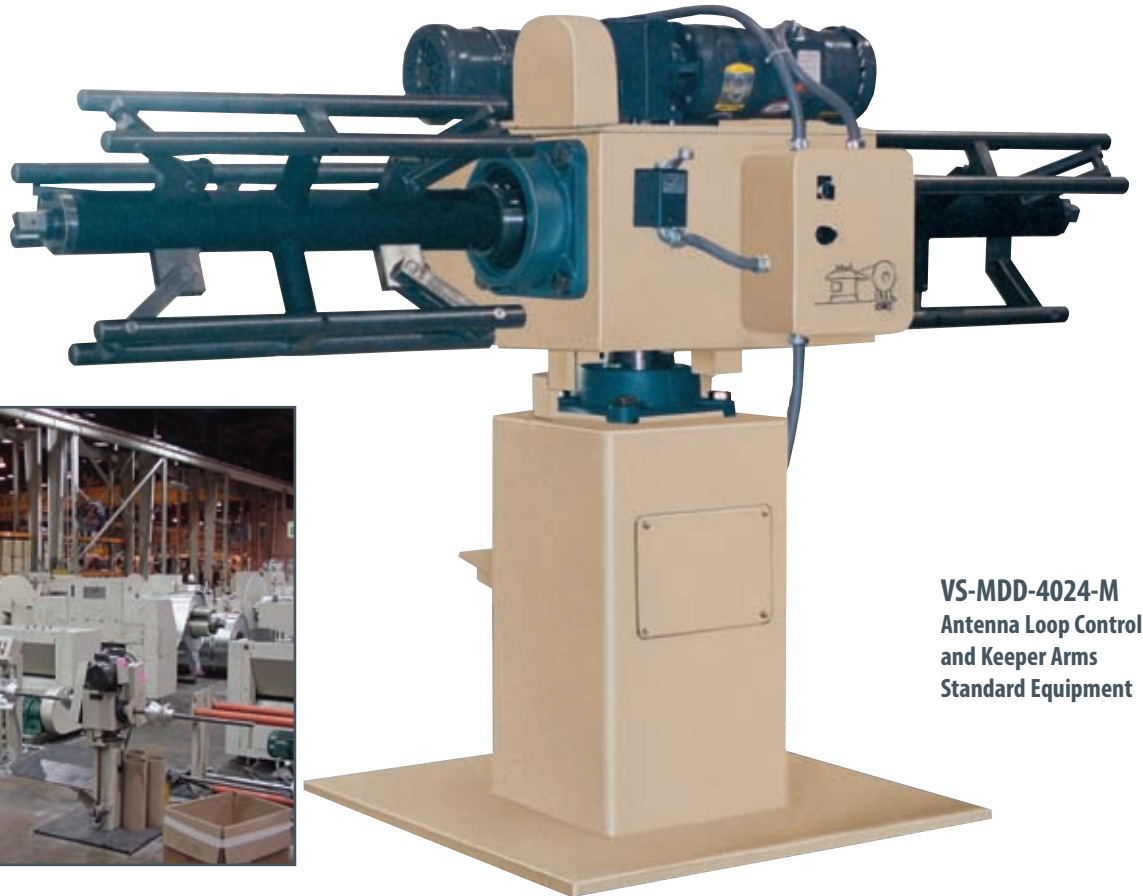

VS-MDD-4024-M
Antenna Loop Control
and Keeper Arms
Standard Equipment



Flat Stock Straighteners: Nonmotorized

Productivity Performers...

Everything you need around your press to make it work better, faster, more efficiently.

Model SC Nonmotorized

When your material application requires straightening metals up to 12" in width and from .008"-.100" in thickness, The Durant SC series sets the standard for the industry. All models include (2) entrance drive rolls and (7) straightening rolls. The rolls are individually adjusted, enabling precise fine tune straightening of your material. All rolls are precision ground and heat treated for long term problem free service.

FEATURES:

- Open top feature for ease of cleaning rolls and threading material
- All rolls precision ground and heat treated
- Each roll individually adjustable for precise fine tune straightening of your material
- Entrance and exit guide rollers
- Black oxide machine finish



SC-107



SC-107

OPTIONS:

- Variable speed motorized models
- Roll dial indicators for roll positioning

BENEFITS:

- Precise fine tune straightening of material
- (3) Year Warranty
- Versatile machine to handle many types of materials and material thickness

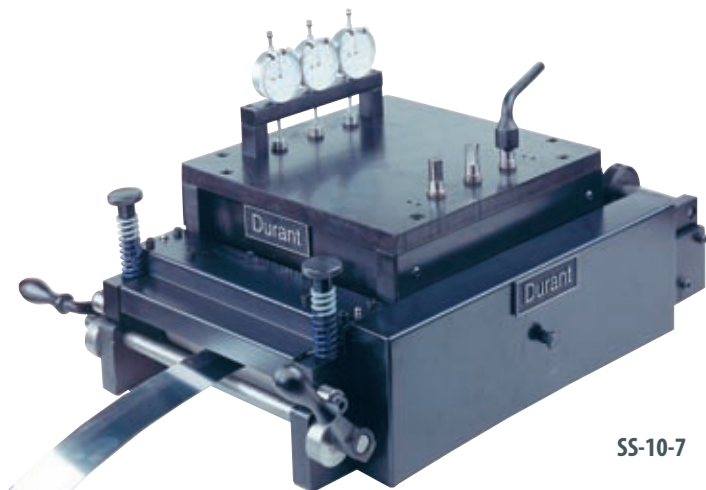

SS-10-7

Model SS & MS Nonmotorized

The SS and MS series Unmotorized Stock Straighteners are ideal machines for either manually straightening materials with a hand crank or automatic pull through operations. Twenty-eight models are available with capabilities to 36" in width and .210 in thickness. All machines include (5) or (7) straightening rolls and (2) drive rolls.



SC UNMOTORIZED

Model	Width	No. Drive Rolls	Straightening Rolls	Roll Diameter	Thickness Range
SC-10	3 1/8"	2	5	1"	.008-.100
SC-107	3 1/8"	2	7	1"	.008-.100
SC-2	6"	2	5	1"	.008-.100
SC-27	6"	2	7	1"	.008-.100
SC-57	12"	2	7	1 1/4"	.010-.065

SS, MS UNMOTORIZED

Model	Width	No. Drive Rolls	Straightening Rolls	Roll Diameter	Thickness Range
SS-6-5	6"	2	5	2"	.020-.145"
SS-6-7	6"	2	7	2"	.020-.145"
SS-10-5	10"	2	5	2"	.020-.130"
SS-10-7	10"	2	7	2"	.020-.130"
SS-15-5	15"	2	5	2"	.020-.110"
SS-15-7	15"	2	7	2"	.020-.110"
SS-20-5	20"	2	5	2"	.020-.090"
SS-20-7	20"	2	7	2"	.020-.090"
SS-25-5	25"	2	5	2"	.020-.065"
SS-25-7	25"	2	7	2"	.020-.065"
SS-30-5	30"	2	5	2"	.020-.055"
SS-30-7	30"	2	7	2"	.020-.055"
SS-36-5	36"	2	5	2"	.020-.040"
SS-36-7	36"	2	7	2"	.020-.040"
MS-6-5	6"	2	5	2 3/4"	.025-.210"
MS-6-7	6"	2	7	2 3/4"	.025-.210"
MS-10-5	10"	2	5	2 3/4"	.025-.190"
MS-10-7	10"	2	7	2 3/4"	.025-.190"
MS-15-5	15"	2	5	2 3/4"	.025-.180"
MS-15-7	15"	2	7	2 3/4"	.025-.180"
MS-20-5	20"	2	5	2 3/4"	.025-.160"
MS-20-7	20"	2	7	2 3/4"	.025-.160"
MS-25-5	25"	2	5	2 3/4"	.025-.130"
MS-25-7	25"	2	7	2 3/4"	.025-.130"
MS-30-5	30"	2	5	2 3/4"	.025-.100"
MS-30-7	30"	2	7	2 3/4"	.025-.100"
MS-36-5	36"	2	5	2 3/4"	.025-.080"
MS-36-7	36"	2	7	2 3/4"	.025-.080"

Flat Stock Straighteners: Motorized

Model VS-MSC Vari Speed - Open Top

If your application calls for straightening materials up to 12" in width, and from .008" to .100" in thickness, the Durant VS-MSC Series sets the standard for the metal stamping industry. All models include entrance drive rolls, straightening rolls, and variable speed DC drive. These individually adjustable rolls are precision ground and heat treated for long term service. Entrance and exit adjustable guide roller assembly is standard equipment.

VS-MSC VARI SPEED MOTORIZED						
Model	Width	No. Drive Rolls	No. Straight. Rolls	Roll Diameter	Motor	Thickness Range
VS-MSC-10	3 1/8"	2	5	1"	3/4 HP	.008-.100
VS-MSC-107	3 1/8"	2	7	1"	3/4 HP	.008-.100
VS-MSC-2	6"	2	5	1"	3/4 HP	.008-.100
VS-MSC-27	6"	2	7	1"	3/4 HP	.008-.100
VS-MSC-57	12"	2	7	1 1/4"	1 HP	.008-.065

Special Features:
Open top for ease of cleaning rolls and threading materials.

FEATURES:

- Rugged steel frame construction
- Open top feature for ease of cleaning rolls and threading material
- Inclined straightening head
- All rolls precision ground and heat treated
- Each roll individually adjustable for precise fine tune straightening of your material
- Entrance and exit guide rollers
- Material support rollers
- Black oxide machine finish
- Automatic speed controller
- Variable speed dancer type loop controller
- Heavy duty gear reducer

OPTIONS:

- Roll dial indicators for roll positioning
- Variable speed antenna type loop controller
- A-1 Sonic no touch loop controller

BENEFITS:

- Precise fine tune straightening of material
- (3) Year Warranty
- Versatile machine to handle many types of materials and material thickness

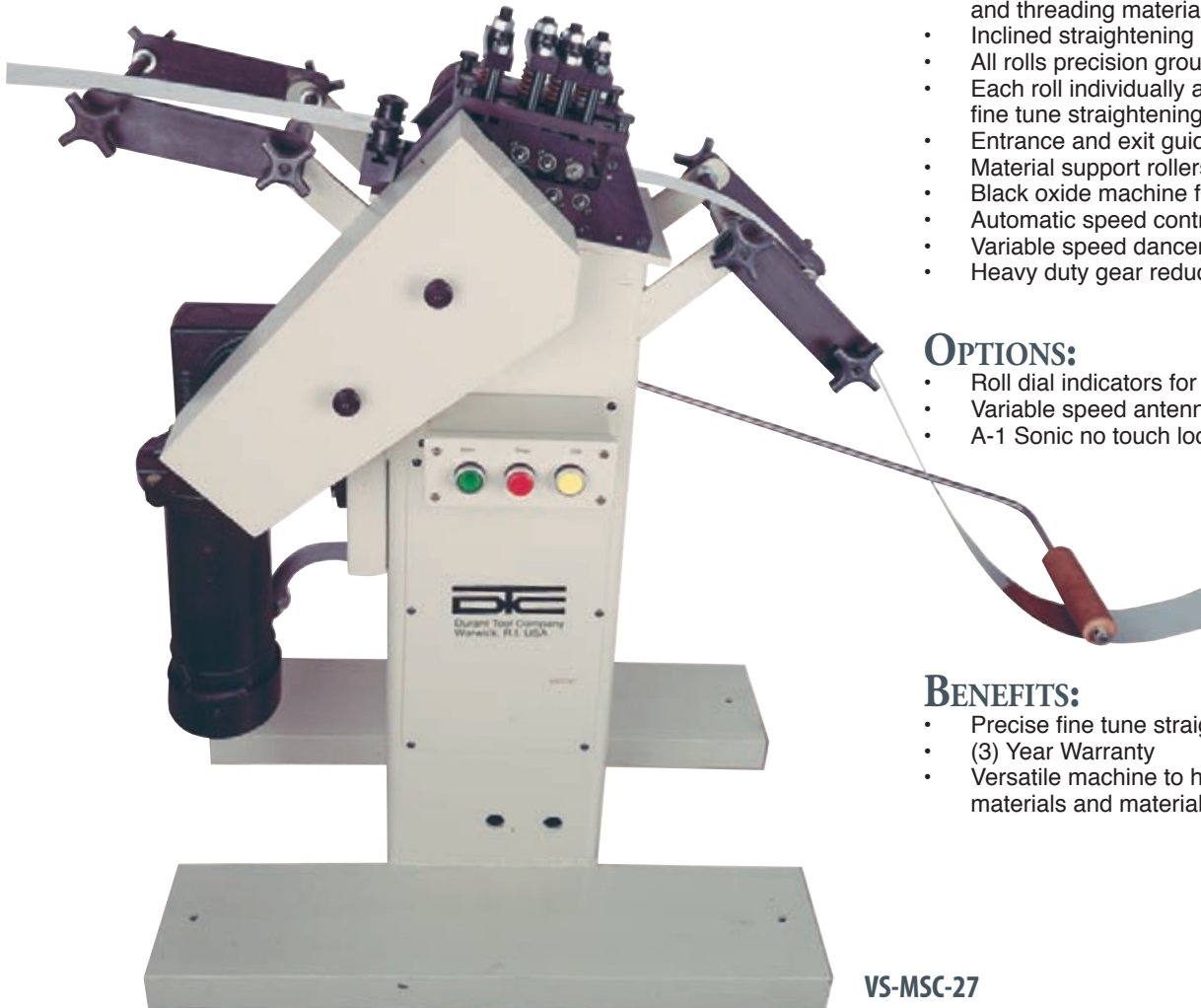

VS-MSC-27

Flat Stock Straighteners: Motorized

Combination Decoiler / Straighteners DSC/ MSC

When saving floor space is a necessity. The Durant model DSC / MSC is your choice. Three models are available with weight capacities to 1200 lbs. and material widths to 12".

All models have (7) straightening rolls and (2) drive rolls to precisely straighten your material. A quick response variable speed DC Drive and proportional loop control allows for speeds from 0 - 90 FPM.

Durant's unique electronic drives give the user a smooth, accurate, loop of material which prevents coil marking.



DSC-1/MSC-27

FEATURES:

- Heavy Duty Steel Frame Construction
- 2" Diameter Main Spindle Shaft
- (2) Heavy Duty Main Spindle Bearings
- Variable Speed Dancer Type Material Loop Control
- Heavy Duty Gear Reducer
- Entrance and Exit Guide and Material Support Rollers
- Black Oxide Finish: Standard Equipment

OPTIONS:

- Variable Speed Antenna Type Loop Control
- A-1 Sonic Type No Touch Loop Control

BENEFITS:

- Space Saving Combination Machine
- Easy to move within factory with forklift
- Smooth Payout of your materials
- Heavy Duty, Rugged Frame Construction for long trouble free operation
- Easy Loading of Coils
- Highest Quality Components
- (3) Year Warranty
- Versatile machine that handles most Press, Roll Forming, Wire Forming, Uncoiling applications

COMBINATION REEL / STRAIGHTENER DSC / MSC									
Model	Max. Width	Max. Coil O.D.	Max. Coil Weight	Straightening Capacity	No. Drive Rolls	No. Straight. Rolls	Roll Diameter	Motor	Stn. Speed
DSC-1/MSC27	6"	36"	600 lbs.	.008-.100"	2	7	1"	3/4 H.P. 90 vdc	0-90 FPM
DSC-2/MSC27	6"	48"	1200 lbs.	.008-.100"	2	7	1"	3/4 H.P. 90 vdc	0-90 FPM
DSC-2/MSC57	12"	48"	1200 lbs.	.008-.065"	2	7	1 1/4"	1 H.P. 90 vdc	0-90 FPM

Heavy Duty Combo Decoiler Flat Stock Straightener

When saving floor space is a necessity, the Durant Straightener/Decoiler should be your choice. Heavy duty construction with the finest machined components guarantees a long term trouble-free investment.

Durant offers models in weight capacities to 4000 lbs. Material widths are available to 36" and material thickness to .190".

Our quick response variable speed drive to 150 feet per minute can be ordered.

Our standard loop sensing arm automatically adjusts material payout speed to your press requirements. All units are equipped with entrance and exit drive rolls and cascade rolls. It is necessary to specify left to right or right to left stock travel.

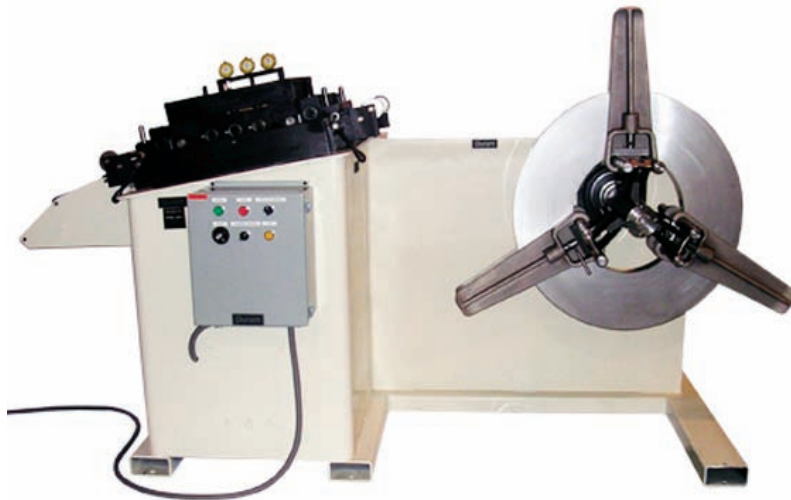

FEATURES:

- Heavy Duty Steel Frame Construction
- (2) Heavy Duty Main Spindle Bearings
- Variable Speed Dancer Type Material Loop Control
- Heavy Duty Gear Reducer
- Roll Adjust Dial Indicators
- Entrance and Exit Guide and Material Support Rollers
- Black Oxide Finish: Standard Equipment

OPTIONS:

- Variable Speed Antenna Type Loop Control
- A-1 Sonic Type No Touch Loop Control

BENEFITS:

- Space Saving Combination Machine
- Easy to move within factory with forklift
- Smooth Payout of your materials
- Heavy Duty, Rugged Frame Construction for long trouble free operation
- Easy Loading of Coils
- Highest Quality Components
- (3) Year Warranty
- Versatile machine that handles most Press, Roll Forming, Wire Forming, Uncoiling and Rewinding applications

Model	Coil Weight Capacity	Max. Width	Max. Material Thickness	Maximum Coil O.D.	Coil I.D.	Number Rolls	Motor
VS-SR12-20-M	2000 lbs.(909kg)	12"	.135"	54"	15"-20"	11	2 HP
VS-SR24-20-M	2000 lbs.(909kg)	24"	.065"	54"	15"-20"	11	2 HP
VS-SR30-20-M	2000 lbs.(909kg)	30"	.055"	54"	15"-20"	11	2 HP
VS-SR36-20-M	2000 lbs.(909kg)	36"	.040"	54"	15"-20"	11	2 HP
VS-SR12-30-M	3000 lbs.(1364kg)	12"	.135"	60"	15"-20"	11	2 HP
VS-SR24-30-M	3000 lbs.(1364kg)	24"	.065"	60"	15"-20"	11	2 HP
VS-SR30-30-M	3000 lbs.(1364kg)	30"	.055"	60"	15"-20"	11	2 HP
VS-SR36-30-M	3000 lbs.(1364kg)	36"	.040"	60"	15"-20"	11	2 HP
VS-SR12-40-M	4000 lbs.(1818kg)	12"	.135"	60"	15"-20"	11	2 HP
VS-SR24-40-M	4000 lbs.(1818kg)	24"	.065"	60"	15"-20"	11	2 HP
VS-SR30-40-M	4000 lbs.(1818kg)	30"	.055"	60"	15"-20"	11	2 HP
VS-SR36-40-M	4000 lbs.(1818kg)	36"	.040"	60"	15"-20"	11	2 HP
VS-SR12-20-H	2000 lbs.(909kg)	12"	.190"	54"	15"-20"	11	3 HP
VS-SR24-20-H	2000 lbs.(909kg)	24"	.130"	54"	15"-20"	11	3 HP
VS-SR30-20-H	2000 lbs.(909kg)	30"	.100"	54"	15"-20"	11	3 HP
VS-SR36-20-H	2000 lbs.(909kg)	36"	.080"	54"	15"-20"	11	3 HP
VS-SR12-30-H	3000 lbs.(1364kg)	12"	.190"	60"	15"-20"	11	3 HP
VS-SR24-30-H	3000 lbs.(1364kg)	24"	.130"	60"	15"-20"	11	3 HP
VS-SR30-30-H	3000 lbs.(1364kg)	30"	.100"	60"	15"-20"	11	3 HP
VS-SR36-30-H	3000 lbs.(1364kg)	36"	.080"	60"	15"-20"	11	3 HP
VS-SR12-40-H	4000 lbs.(1818kg)	12"	.190"	60"	15"-20"	11	3 HP
VS-SR24-40-H	4000 lbs.(1818kg)	24"	.130"	60"	15"-20"	11	3 HP
VS-SR30-40-H	4000 lbs.(1818kg)	30"	.100"	60"	15"-20"	11	3 HP
VS-SR36-40-H	4000 lbs.(1818kg)	36"	.080"	60"	15"-20"	11	3 HP

Flat Stock Straighteners: Motorized

Heavy Duty Straightening Machines

Durant's motorized medium and heavy duty stock straighteners have one set of entrance drive rolls, one set of exit drive rolls, and seven straightening rolls for a total of eleven rolls. All entrance, exit, and lower straightening rolls are power driven. Standard equipment on all models are 220/440-60 cycle, 3 phase motorization, vari drive of 0 to 100 FPM (other speeds can be supplied), loop controller, dial indicators, inclined head, cascade rolls, black oxide finish. Solidly welded contemporary cabinets, with one easily removable access panel, allows for your maintenance department to inspect and adjust drive components and chains with ease.

VS Drive Features and Benefits:

- Antenna-Tracker™ loop controller. This self adjusting state of the art control system allows a loop of material to move up and down between the two control antennas providing a smooth and stable running machine. Increasing and decreasing line speeds will automatically increase or decrease the straighteners speed by the simple touch of an antenna!
- State of the Art Regenerative drive controller to insure fast acceleration and immediate stopping capability upon demand. Standard speed range is 0-100 F.P.M.
- Operator friendly controls with Power Start, Stop, Auto/Manual, Forward/ Reverse & Jog push buttons to allow the press operator to easily thread and run the line while insuring optimum safety.

MD VARIABLE SPEED						
Model	Max. Width	Max. Thickness	Min. Thickness	Roll Diameter	Roll Spacing	Motor
VS-MD-6	6"	.145"	.020"	2"	2 1/4"	2 HP
VS-MD-10	10"	.130"	.020"	2"	2 1/4"	2 HP
VS-MD-15	15"	.110"	.020"	2"	2 1/4"	2 HP
VS-MD-20	20"	.090"	.020"	2"	2 1/4"	2 HP
VS-MD-25	25"	.065"	.020"	2"	2 1/4"	2 HP
VS-MD-30	30"	.055"	.020"	2"	2 1/4"	2 HP
VS-MD-36	36"	.040"	.020"	2"	2 1/4"	2 HP
HD VARIABLE SPEED						
Model	Max. Width	Max. Thickness	Min. Thickness	Roll Diameter	Roll Spacing	Motor
VS-HD-6	6"	.210"	.025"	2 3/4"	3 1/4"	3 HP
VS-HD-10	10"	.190"	.025"	2 3/4"	3 1/4"	3 HP
VS-HD-15	15"	.180"	.025"	2 3/4"	3 1/4"	3 HP
VS-HD-20	20"	.160"	.025"	2 3/4"	3 1/4"	3 HP
VS-HD-25	25"	.130"	.025"	2 3/4"	3 1/4"	3 HP
VS-HD-30	30"	.100"	.025"	2 3/4"	3 1/4"	3 HP
VS-HD-36	36"	.080"	.025"	2 3/4"	3 1/4"	3 HP
VS-HD-42	42"	.060"	.025"	2 3/4"	3 1/4"	3 HP
VS-HD-48	48"	.040"	.025"	2 3/4"	3 1/4"	3 HP

STANDARD SPEED: 0-100 FPM

OPTIONS: • Heavy Duty Portable Feature • No Touch Loop Control

Heavy Duty Straightening Machines

Virtually Every Type of Metal Stamping Accessory to Help your Production Run Better!

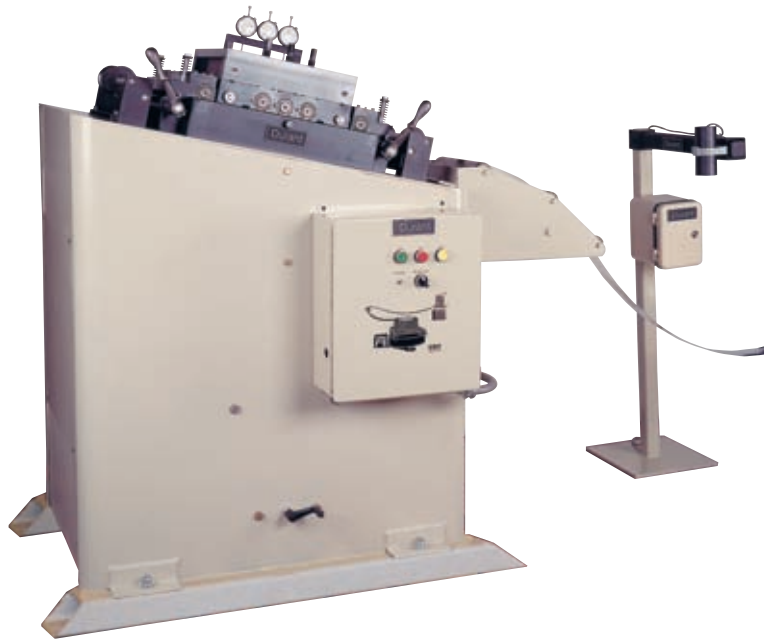

Standard Features:

- Inclined Head
- Antenna Loop Controller
- Dial Indicators
- Black Oxide Finish
- Cascade Rolls
- Extra Heavy Duty Cabinet

VS-MD-10

VS-MD-10 with antenna control
standard Option: Sonic no touch
loop control as shown above.



VS-HD-25

VS HD-25 without inclined head.
Inclined head is standard equipment.

Material Loop Controllers

CLC-1 and VS-CLC-1 Contact Loop Control

Now there is a perfect contact sensor auxiliary for straighteners, reels or other machinery where a loop of material must be regulated with exact precision -- the Contact Loop Control from Durant. With this unit all that's required to control the slack of your loop is the movement of adjustable contacts. Installation is not complicated. Voltage must be compatible with the equipment which is being controlled. If voltage is not specified, 110 Volt is supplied.

A-1 Sonic Type NO Contact Loop Control

- The only PATENTED analog output NON-CONTACT loop control NOT limited to loop control application.
- Can be used to control levels of liquids or solids in tanks.
- Can be used to control unwind and rewind tension.
- Can be used to detect the presence or absence of pallets in automated warehouses.
- Can measure changes in distance as small as .10".
- Now comes in many models with a variety of standard and optional features that allow you to configure the optimum NON-CONTACT, sensing and control system for your application.

Durant offers a wide selection of contact and non-contact controls to sense and precisely control the loop material of your processing production equipment. While we specialize in stock reeling, coil straightening and rewinding equipment, Durant's contact and non-contact electronic sensors can be adapted to a large variety of manufacturing requirements. Call us with your problems and we will work together to increase your factory productivity. Call Durant for additional assistance.



Contact Control CLC-1
Contact Control VS-CLC-1



A-1 No Contact Control

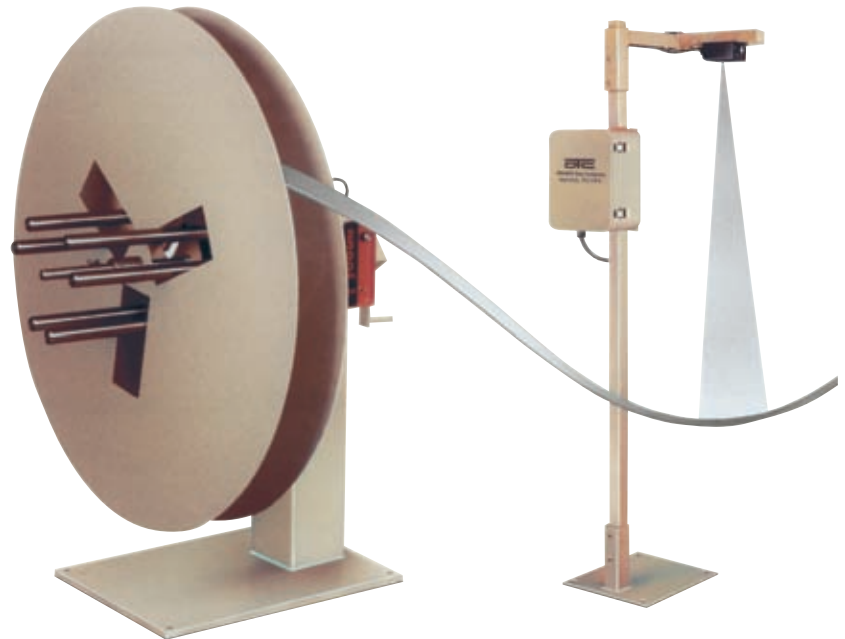

A-1 No Contact Loop Control

NO CONTACT SONIC LOOP CONTROL	
Model	Motorization to be Utilized With
A-1	115 Volt AC or DC Motors or 230 Volt AC or DC Motors
CONTACT LOOP CONTROL	
Model	Type
CLC-1	On/Off Ground Type
VS-CLC-1	Variable Speed Ground Type

Pneumatic Parts/Piece Transporters

Durant Pneumatic Parts Transporters



(4) Weight Capacities to 220 lbs. To Meet Most Part Transporting Requirements.

When your manufacturing process calls for the movement of parts and pieces, it's time to call Durant.

1. Durant offers a complete line of rugged pneumatic parts transporters.
2. Durant's selection of air operated transporters can transport to a weight capacity of 220 lbs. at speeds up to 35FPM.
3. Durant's transporters allow you to fit the conveying tray in very small, tight manufacturing spaces.
4. Durant transporters have no mechanical springs. Simple and easy to install and maintain.
5. Durant offers a standard 3 Year warranty on all transporters.
6. Durant product engineering, quality, manufacturing and components are Rated # 1
7. Durant pricing is always at the most competitive levels.
8. Durant customer service specialists are a team focusing on your needs. We're Not Satisfied Until You Are!

The Durant pneumatic transporter is designed with a pneumatic cylinder that slowly accelerates in the forward stroke, moving the material forward. The rapid return stroke insures that the material remains stationary, ensuring a constant movement in one direction of your materials or parts.

The design of the Durant transporter allows you install the machine and tray in very small, tight manufacturing spaces.

All Durant transporters may be installed with multiple trays, eliminating the use of conventional belt conveyors. It's simple, rugged design makes the Durant pneumatic transporter the cost effective, reliable, productivity performer.

FEATURES:

- 3 Year Warranty
- Speeds to 35FPM
- Rugged, Quality Construction
- Simple, Easily Installed and Operated
- Weight Capacities to 220 Lbs.
- Multiple Trays may be installed on one transporter

Durant Pneumatic Parts Transporters			
Model	Transportation Capacity	Max. Stroke Lengths	Recommended Strokes per min.
GLT-12	26 lbs.	.9 in	120
GLT-24	53 lbs.	.9 in	110
GLT-48	106 lbs.	1.1 in	110
GLT-100	220 lbs.	1.1 in	100

Model	Maximum Tray Weight	Air Consumption	Air Pressure	Feed Rate
GLT-12	6 lbs.	12L/Min	60-80 PSI	29-35 FPM
GLT-24	9 lbs.	32L/Min	60-80 PSI	29-35 FPM
GLT-48	12.75 lbs.	46L/Min	60-80 PSI	29-35 FPM
GLT-100	44 lbs.	130L/Min	60-80 PSI	29-35 FPM

Model	Max Incline of Chute	Sound Level	Weight
GLT-12	8°	68 dB-A	5 ½ lbs.
GLT-24	8°	68 dB-A	9 lbs.
GLT-48	8°	68 dB-A	14 lbs.
GLT-100	8°	68 dB-A	40 lbs.

Durant Pneumatic Parts Transporters

Tray Options		
OPTION A SMALL	OPTION B MEDIUM	OPTION C LARGE
Add: \$125.00	Add: \$160.00	Add \$190.00

Tray Support Wheels: No Charge

Heavy Duty Motorized Scrap Cutters



MSC-600



MSC-1000

Heavy Duty Motorized Scrap Cutters

Model MSC Motorized

Our scrap cutters can give you twice the life you would get with any shearing-cut (reciprocating-cut) machine. And we have proven it in the field... hundreds of times.

It is because these units let you perform high accuracy cutting of thickness from .002" without a clearance adjustment. It is because regular greasing is the only maintenance these machines require. It is because these machines typically run two to three years between blade sharpening.

But durability is just where the advantages of these patented waving-cut machines begin. They are also easy to use and have been designed so they will not damage presses, dies or feed gears under any circumstances. They can be set up to suit your operation with the motor mounted on either the top or bottom of the cutting frame.

Features:

- Tool life is several times as long as that for shearing-cut (reciprocating cut) machines.
- Greasing is the only maintenance requirement.
- The machines are designed on many years experience. Various improvement suggested by users have been introduced for higher efficiency and convenience in practical use.
- These patented waving-cut machines are simple in construction, yet very durable.
- High-accuracy cutting of thickness from 0.002" is ensured without tool clearance adjustment.
- It is not necessary for the machines to be synchronized with presses and require little floor space.
- There is no possibility for presses, dies or feed gears to be damaged by the machines.
- Heavy duty machines with no equal in the metal stamping industry.
- 2-3 Years between blade sharpening.
- All models available with motor mounted on either top or bottom of cutting frame.

MODEL MSC CUTTERS		
MODEL	CUTTING CAPACITY THICKNESS X WIDTH	MOTOR OUTPUT RPM (50HZ/60HZ)
MSC-01	.032 x 1.96	0.1 kw 85
MSC-01-SR	.040 x 1.96	0.1 kw 85
MSC-05	.048 x 3.00	0.2 kw 102
MSC-05-SR	.056 x 3.00	0.2 kw 102
MSC-05-W	.048 x 4.25	0.2 kw 102
MSC-1-J	.048 x 5.80	0.4 kw 116
MSC-1-J-ST	.072 x 3.50	0.4 kw 102
MSC-1-J-W	.048 x 7.45	0.4 kw 102
MSC-1	.072 x 5.80	0.75 kw 116
MSC-1-SR	.080 x 5.80	0.75 kw 102
MSC-1-ST	.104 x 3.50	0.75 kw 102
MSC-1-W	.072 x 7.45	0.75 kw 102
MSC-1-SW	.056 x 11.75	0.75 kw 102
MSC-150-J	.136 x 5.50	1.5 kw 102
MSC-200-J	.120 x 7.45	1.5 kw 102
MSC-250-J	.096 x 9.42	1.5 kw 102
MSC-300-J	.092 x 11.75	1.5 kw 102
MSC-2	.080 x 14.50	1.5 kw 102
MSC-150	.192 x 5.80	2.2 kw 83
MSC-200	.168 x 7.45	2.2 kw 83
MSC-250	.160 x 9.42	2.2 kw 83
MSC-300	.128 x 11.75	2.2 kw 83
MSC-2-SR	.120 x 15.70	2.2 kw 83
MSC-500	.100 x 19.50	2.2 kw 83
MSC-600	.080 x 23.50	2.2 kw 83
MSC-150-SR	.240 x 5.80	3.7 kw 83
MSC-200-SR	.200 x 7.85	3.7 kw 83
MSC-300-SR	.180 x 11.75	3.7 kw 83
MSC-2-ST	.144 x 15.70	3.7 kw 83
MSC-500-SR	.136 x 19.50	3.7 kw 83
MSC-600-SR	.120 x 23.50	3.7 kw 83
MSC-800-SR	.164 x 31.00	3.7 kw 83
MSC-1000-SR	.080 x 39.25	3.7 kw 83



MSC-800-SR



MSC-1

Wire Uncoilers

Uncoiling wire is simple and trouble-free when using the Durant Variable Speed Motorized Wire Payoffs. Only the Durant Wire Payoff eliminates the problems associated with wire twists and tangles. The positive drive system smoothly pays out the wire through a heavy duty guiding system with built in accumulator. The “quick response” regenerative drive feeds the wire accurately to your wire forming machine. If your wire stands are loaded in the opposite manner, a flip of the switch quickly reverses the turntable rotation.

Features:

- Wire stand locks.
- Accumulator / wire guide.
- Regenerative drive / braking.
- Coil stand lock.
- Heavy Duty Steel Frame Construction
- Rugged 1/2” Thick Solid Steel Turntable. Will not deflect or dent with forklift loading
- (2) Heavy Duty Main Spindle Support Bearings
- Heavy Duty Gear Reducer
- Reverse Turntable direction with flip of the switch. No mechanical adjustments or torque systems to install
- No drive wheels that wear and slip
- Requires no slack loop. Can be placed within 2-3 feet of wire forming machine depending on the application
- Easy loading of wire coils
- Easy to move within factory
- Automatic material speed controller
- Manual speed control over ride feature
- No Dangerous Turntable Pinch Points. (Note: Other manufactures have many casters and drive wheels under the turntable creating dangerous pinch points for operator’s fingers.)

No Mechanical Contraptions to Fool with!
No Drive Wheels that Wear and Slip!

From
\$4900⁰⁰

Options:

- Wire Retaining Basket on Turntable.
- Adjustable Inside Coil Diameter Coil Rods.
- Horizontal Top and Bottom Roller Guide Assembly on Adjustable Height Pole.
- Vertical Roller Guide Assembly on Adjustable Height Pole.
- Special color (black standard).
- Larger turntable diameter and/or weight capacity.
- Faster Turntable speeds to 75RPM.
- Turntable Diameters to 72” O.D.
- Larger weight capacities
- Rubber Anti –Slip Turntable Mat Option
- Casters for mobility and portability
- Zero Speed/E Stop Air Brake system

Benefits:

- Increase Worker Productivity
- Easy Loading of Wire Coils
- Smooth Payout and Uncoiling of your material
- Heavy Duty Steel Frame Construction for Long Trouble Free Operation
- Highest Quality Components
- (3) Year Warranty
- Versatile machine that handles many Wire Uncoiling applications

WIRE UNCOILER SPECIFICATIONS					
Model	Weight Capacity	Max. Wire Diameter	Max. Turntable RPM	Turntable Diameter	Motor H.P.
W-525-30-M	500 lbs.	.156”	0-25	30”	1/2
W-550-30-M	500 lbs.	.156”	0-50	30”	1/2
W-525-36-M	500 lbs.	.156”	0-25	36”	1/2
W-550-36-M	500 lbs.	.156”	0-50	36”	1/2
W-1025-30-M	1000 lbs.	.156”	0-25	30”	3/4
W-1050-30-M	1000 lbs.	.156”	0-50	30”	3/4
W-1025-36-M	1000 lbs.	.156”	0-25	36”	3/4
W-1050-36-M	1000 lbs.	.156”	0-50	36”	3/4
W-1025-42-M	1000 lbs.	.156”	0-25	42”	3/4
W-1050-42-M	1000 lbs.	.156”	0-50	42”	3/4
W-2025-42-M	2000 lbs.	.156”	0-25	42”	3/4
W-2050-42-M	2000 lbs.	.156”	0-50	42”	3/4
W-2025-48-M	2000 lbs.	.156”	0-25	48”	3/4
W-2050-48-M	2000 lbs.	.156”	0-50	48”	3/4
W-3525-48-M	3500 lbs.	.156”	0-25	48”	3/4
W-3550-48-M	3500 lbs.	.156”	0-50	48”	3/4
W-3525-54-M	3500 lbs.	.156”	0-25	54”	3/4
W-3550-54-M	3500 lbs.	.156”	0-50	54”	3/4
W-5025-48-M	5000 lbs.	.156”	0-25	48”	1
W-5050-48-M	5000 lbs.	.156”	0-50	48”	1
W-5025-60-M	5000 lbs.	.156”	0-25	60”	1
W-5050-60-M	5000 lbs.	.156”	0-50	60”	1

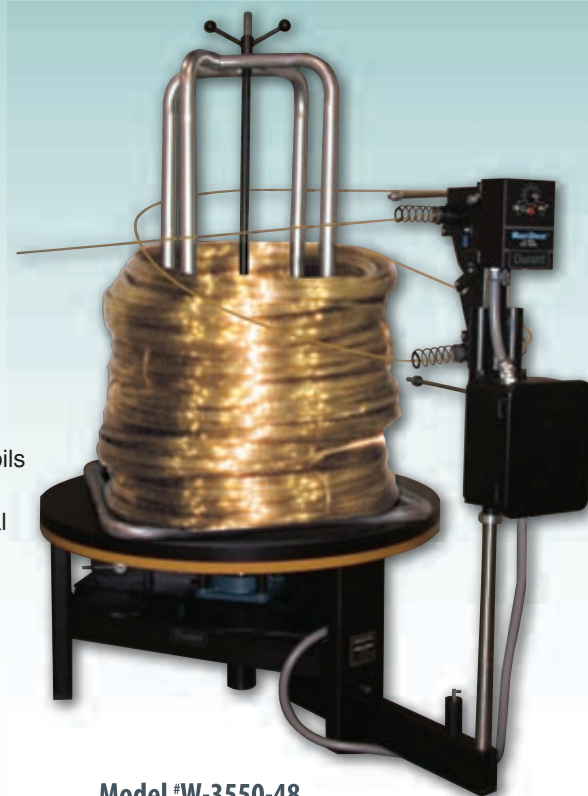

Model #W-3550-48

You make \$\$\$ with the Durant Wire Payoff and Uncoilers. Durant Uncoilers are Productivity Performers! We Guarantee it!



Heavy Duty Wire Uncoilers

Uncoiling wire is simple and trouble-free when using the Durant Variable Speed Motorized Wire Payoffs. Only the Durant Wire Payoff eliminates the problems associated with wire twists and tangles. The positive drive system smoothly pays out the wire through a heavy duty guiding system with built in accumulator. The “quick response” regenerative drive feeds the wire accurately to your wire forming machine. If your wire stands are loaded in the opposite manner, a flip of the switch quickly reverses the turntable rotation.

Features:

- Wire stand locks.
- Accumulator / wire guide.
- Regenerative drive / braking.
- Coil stand lock.
- Speed Sensor (No Potentiometer).
- Heavy Duty Steel Frame Construction
- Rugged 1/2" Thick Solid Steel Turntable. Will not deflect or dent with forklift loading
- (2) Heavy Duty Main Spindle Support Bearings
- Heavy Duty Gear Reducer
- Reverse Turntable direction with flip of the switch. No mechanical adjustments or torque systems to install
- No drive wheels that wear and slip
- Requires no slack loop. Can be placed within 2-3 feet of wire forming machine depending on the application
- Easy loading of wire coils
- Easy to move within factory
- Automatic material speed controller
- Manual speed control over ride feature
- No Dangerous Turntable Pinch Points. (Note: Other manufactures have many casters and drive wheels under the turntable creating dangerous pinch points for operator's fingers.)



Options:

- Adjustable Inside Coil Diameter Coil Rods.
- Horizontal Top and Bottom Roller Guide Assembly on Adjustable Height Pole.
- Vertical Roller Guide Assembly on Adjustable Height Pole.
- Faster Turntable speeds to 75RPM.
- Turntable Diameters to 72" O.D.
- Larger weight capacities
- Rubber Anti-Slip Turntable Mat Option
- Custom paint colors to customer specifications
- Casters for mobility and portability
- Zero Speed/E Stop Air Brake system

Benefits:

- Increase Worker Productivity
- Easy Loading of Wire Coils
- Smooth Payout and Uncoiling of your material
- Heavy Duty Steel Frame Construction for Long Trouble Free Operation
- Highest Quality Components
- (3) Year Warranty
- Versatile machine that handles many Wire Uncoiling applications

WHD WIRE UNCOILERS

Model	Weight Capacity	Max. Wire Diameter	Turntable RPM	Turntable Dia.	Motor H.P.
WHD 525-30	500 lbs.	.375"	0-25	30"	1/2
WHD 550-30	500 lbs.	.375"	0-50	30"	1/2
WHD 525-36	500 lbs.	.375"	0-25	36"	1/2
WHD 550-36	500 lbs.	.375"	0-50	36"	1/2
WHD 1025-30	1000 lbs.	.375"	0-25	30"	3/4
WHD 1050-30	1000 lbs.	.375"	0-50	30"	3/4
WHD 1025-36	1000 lbs.	.375"	0-25	36"	3/4
WHD 1050-36	1000 lbs.	.375"	0-50	36"	3/4
WHD 1025-42	1000 lbs.	.375"	0-25	42"	3/4
WHD 1050-42	1000 lbs.	.375"	0-50	42"	3/4
WHD 2025-42	2000 lbs.	.375"	0-25	42"	3/4
WHD 2050-42	2000 lbs.	.375"	0-50	42"	3/4
WHD 2025-48	2000 lbs.	.375"	0-25	48"	3/4
WHD 2050-48	2000 lbs.	.375"	0-50	48"	3/4
WHD 3525-42	3500 lbs.	.375"	0-25	42"	3/4
WHD 3550-42	3500 lbs.	.375"	0-50	42"	3/4
WHD 3525-48	3500 lbs.	.375"	0-25	48"	3/4
WHD 3550-48	3500 lbs.	.375"	0-50	48"	3/4
WHD 3525-54	3500 lbs.	.375"	0-25	54"	3/4
WHD 3550-54	3500 lbs.	.375"	0-50	54"	3/4
WHD 5025-48	5000 lbs.	.375"	0-25	48"	1
WHD 5050-48	5000 lbs.	.375"	0-50	48"	1
WHD 5025-60	5000 lbs.	.375"	0-25	60"	1
WHD 5050-60	5000 lbs.	.375"	0-50	60"	1

Pedestal/Cabinet Wire Uncoilers

Durant Manufactures (7) Model Pedestal and Cabinet Mounted Variable Speed Motorized Wire Uncoilers in weight capacities from 50lbs. to 750lbs. Heavier weight capacities are available.

All models have a standard height of 34" from the Turntable to the base of the machine. Other heights are available, customer to specify at no additional cost.

The Durant Cabinet Wire Uncoilers are rugged machines that utilize an oversized DC Motor, giving you our customer, a long lasting and trouble free investment.

A light weight variable speed dancer type control arm with wire guides, are standard equipment.

Features:

- (4) Adjustable inside Coil Retainers
- Automatic Wire Speed Controller
- Manual speed control override feature
- Light Weight Dancer Type Wire Speed Controller and Wire Guides
- Heavy Duty Steel Frame Construction
- Heavy Duty Main Shaft Bearings
- 3" Diameter Main Shaft
- Regenerative Drive to enhance Acceleration/Deceleration
- Heavy Duty Gear Reducer

Options:

- Horizontal Top and Bottom Roller Guide Assembly on Adjustable Height Pole.
- Vertical Roller Guide Assembly on Adjustable Height Pole.
- Faster Payout Speeds / Turntable RPM
- Special Weight Capacities
- Special Passline Height
- Special Turntable Diameters



Pedestal Model



Cabinet Model

Benefits:

- Easy Loading of Wire Coils
- Smooth Payout of your materials
- Heavy Duty Steel Cabinet Construction for Long Trouble Free Operation
- Highest Quality Components
- (3) Year Warranty
- Versatile machine that handles many wire uncoiling applications

PEDESTAL WIRE UNCOILERS						
MODEL	MAXIMUM WEIGHT CAPACITY	TURNTABLE DIAMETER	TURNTABLE HEIGHT TO FLOOR	TURNTABLE RPM	WIRE DIAMETER	MOTOR
PWD-50-M	50lbs.	18"	34"	0-25RPM	.005"-.320"	□ H.P. 90 VDC
PWD-100-M	100lbs.	24"	34"	0-25RPM	.005"-.320"	□ H.P. 90 VDC
PWD-200-M	200lbs.	24"	34"	0-25RPM	.005"-.320"	□ H.P. 90 VDC

CABINET WIRE UNCOILERS						
MODEL	MAXIMUM WEIGHT CAPACITY	TURNTABLE DIAMETER	TURNTABLE HEIGHT TO FLOOR	TURNTABLE RPM	WIRE DIAMETER	MOTOR
CWD-100-M	100lbs.	24"	34"	0-25RPM	.005"-.320"	½ H.P. 90 VDC
CWD-250-M	250lbs.	30"	34"	0-25RPM	.005"-.320"	½ H.P. 90 VDC
CWD-500-M	500lbs.	30"	34"	0-25RPM	.005"-.320"	¾ H.P. 90 VDC
CWD-750-M	750lbs.	42"	34"	0-25RPM	.005"-.320"	¾ H.P. 90 VDC



Wire Spool Uncoilers

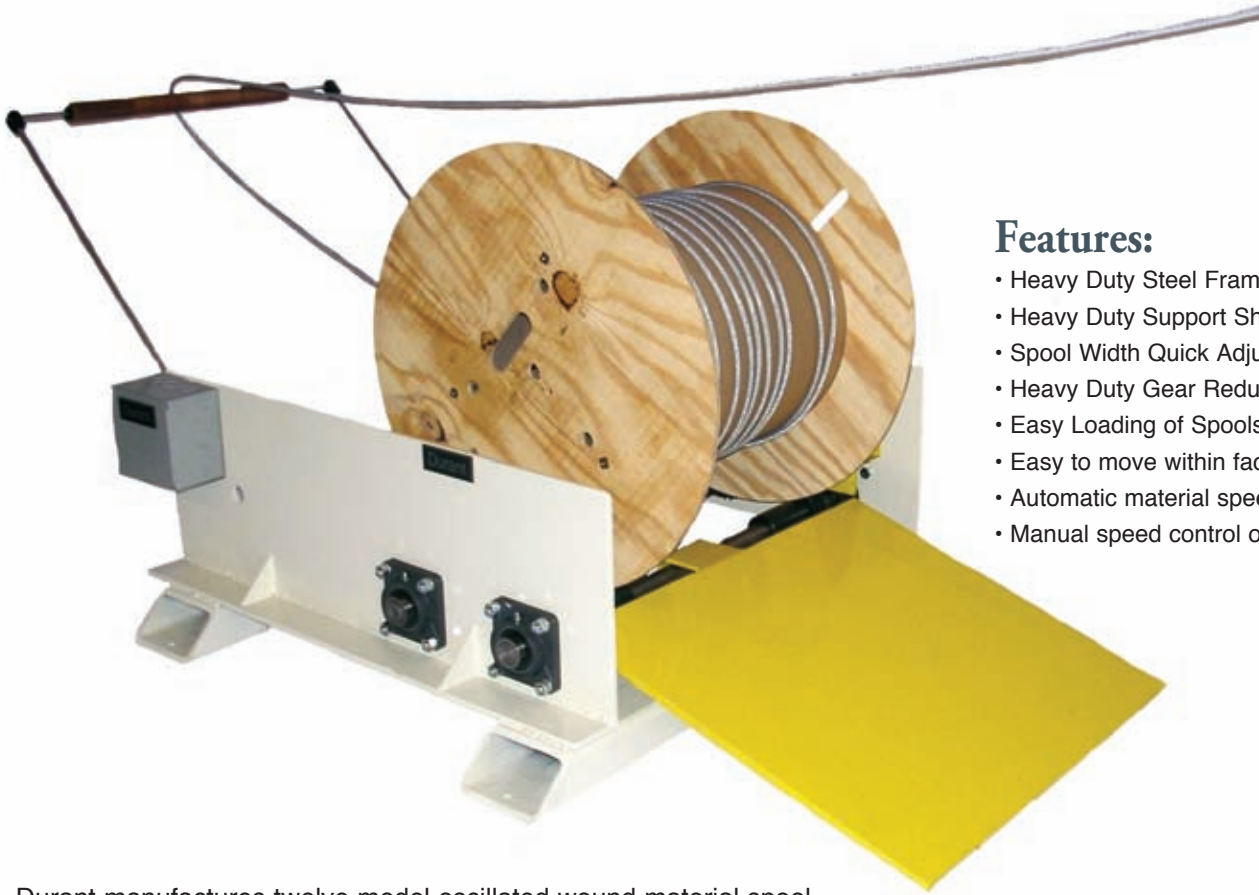

Features:

- Heavy Duty Steel Frame Construction
- Heavy Duty Support Shaft Bearings
- Spool Width Quick Adjustment Guides
- Heavy Duty Gear Reducer
- Easy Loading of Spools with loading ramp
- Easy to move within factory
- Automatic material speed controller
- Manual speed control override feature

Durant manufactures twelve model oscillated wound material spool Decoilers in weight capacities to 5000 LBS and spool widths to 26". All Models are adjustable for a variety of spool widths and rim diameters. A heavy duty variable speed DC motor is used to give you our customer, a long lasting and trouble free investment.

A low profile design and loading ramp is standard equipment on all models, for easy loading.

A light weight variable speed Dancer arm with wire guide is standard on all models.

Options:

- Variable Speed Antenna Type Loop Controller
- Faster Payout Speeds
- Special Spool Widths
- Special Spool Weight Capacities

Benefits:

- Easy Loading of Spools with loading ramp
- Smooth Payout of your material
- Heavy Duty Steel Frame Construction for Long Trouble Free Operation
- Highest Quality Components
- (3) Year Warranty
- Versatile machine that handles most spool uncoiling applications

WSR WIRE SPOOL DECOILERS

Model	Capacity	Spool Rim O.D. Range w/DC Drive Motor HP	Max Spool Width
WSR 217	250 lbs.	12-40" OD 0-100 FPM ½ HP	17"
WSR 226	250 lbs.	12-40" OD 0-100 FPM ½HP	26"
WSR 517	500 lbs.	12-40" OD 0-100 FPM ½HP	17"
WSR 526	500 lbs.	12-40" OD 0-100 FPM ½HP	26"
WSR 1017	1000 lbs.	12-40" OD 0-100 FPM ¾HP	17"
WSR 1026	1000 lbs.	12-40" OD 0-100 FPM ¾HP	26"
WSR 2017	2000 lbs.	12-40" OD 0-100 FPM 1HP	17"
WSR 2026	2000 lbs.	12-40" OD 0-100 FPM 1HP	26"
WSR 3017	3000 lbs.	12-40" OD 0-100 FPM 1HP	17"
WSR 3026	3000 lbs.	12-40" OD 0-100 FPM 1HP	26"
WSR 5017	5000 lbs.	12-40" OD 0-100 FPM 1HP	17"
WSR 5026	5000 lbs.	12-40" OD 0-100 FPM 1HP	26"

TRADITIONAL WIRE STRAIGHTENERS

Model WS Wire Straighteners

Durant Wire Straighteners are used for straightening round or flat wire as well as wire with irregular cross sections. Each unit consists of two sets of 5 or 7 "V" grooved rolls set at right angles as illustrated to remove the material curvature on both planes. The rolls on Durant Wire Straighteners can be grooved to the exact diameter of the wire to be straightened or can be "V"-grooved (standard) for handling a wide range of sizes.

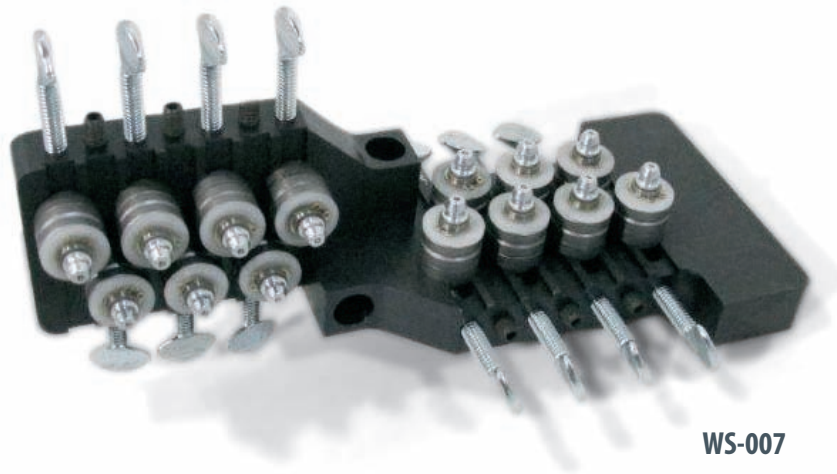

WS-007

Features of Construction:

- Adjustable Rolls - Each roll can be individually adjusted by means of a thumb screw set for proper straightening action.
- Ball Bearing - Each roll is mounted on a hardened Spindle Set in ball bearings for long life.

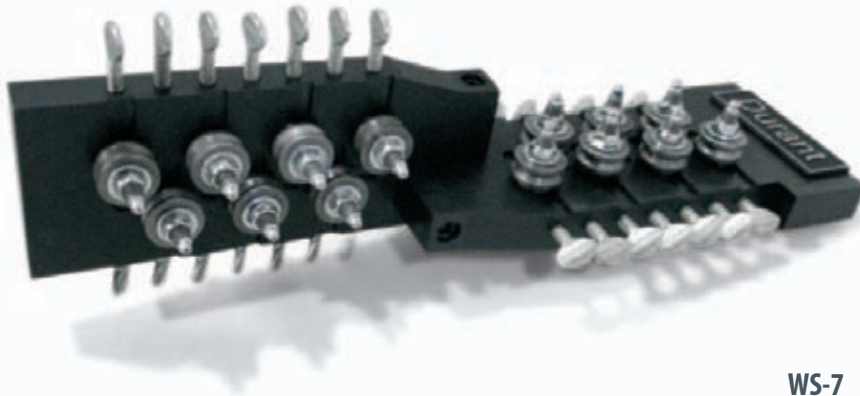

WS-7

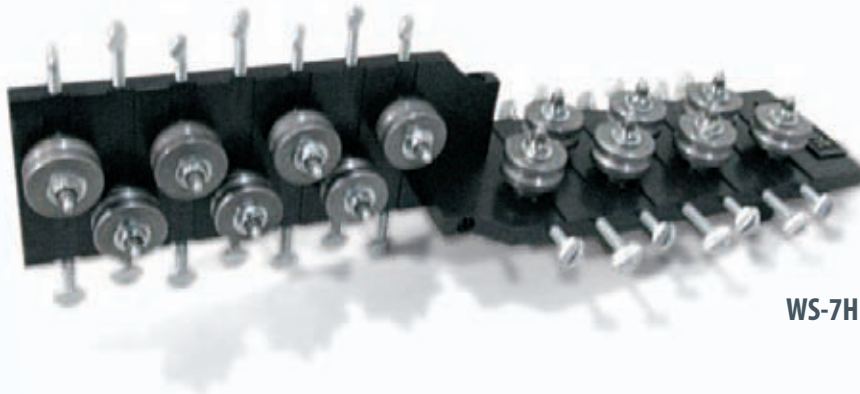

WS-7H

Features:

- All rolls are adjustable enabling you to fine tune the straightening of your material
- All rolls are individually adjusted by means of a thumb screw
- Each roll is set in ball bearings and mounted on a hardened spindle with a grease fitting for proper lubrication and long life
- All machines have a mounting pad for quick and easy mounting to your machine
- Precision Solid Steel CNC Machined Construction

Options:

- All straighteners may be purchased with one plane only
- GW Wire Servo Feeder
- Air Feeder
- Manual Hand Crank Drive Rolls on Stand
- Variable Speed Motorized Drive Rolls
- Special Grooved Rolls

Benefits:

- *Easy to mount on your machine*
- *All Rolls adjustable with a thumb screw to precisely straighten your materials*
- *(3) Year Warranty*
- *Versatile machine that handles most wire straightening applications*

STANDARD WS WIRE STRAIGHTENERS

MODEL	NUMBER OF ROLLS	DIAMETER ROLLS	WIRE SIZE	WEIGHT
WS-007	14	3/4"	Up to .062	8 lbs.
WS-5	10	1 3/16"	Up to .1875	25 lbs.
WS-7	14	1 3/16"	Up to .1875	30 lbs.
WS-5H	10	2 1/4"	Up to .375	60 lbs.
WS-7H	14	2 1/4"	Up to .375	75 lbs.

Quick Adjust E-Series Wire Straightener

The Durant Quick Adjust E-Series Wire Straighteners are ideal straighteners to mount in conjunction with all types of production equipment, including welding machines to straighten your wire. There are two models available, the model EWS-3 for wire diameters up to .052" and the model EWS-3H medium duty model for wire up to .1875".

These high quality wire straighteners have a light weight rugged aluminum body and three hardened "V" groove straightening rolls. All models are equipped with Delrin Guides, a tension knob, fine adjustment scale and locating calibration.

When your straightening requirements call for more than three rolls, you may easily mount a series of these wire straighteners together in either horizontal or vertical planes.



EWS WIRE STRAIGHTENERS			
Model	WIRE DIAMETER UP TO	No. ROLLS	ROLL DIAMETER
EWS-3	.052" (1.3 mm)	3	1 3/16"
EWS-3H	.1875" (4.76 mm)	3	1 3/16"

DIMENSIONS				
Model	HEIGHT	LENGTH	DEPTH	WEIGHT
EWS-3	3" (76.0 mm)	3.5" (90 mm)	1.5" (38 mm)	1 LBS
EWS-3H	3" (76.0 mm)	5.5" (140 mm)	2" (51 mm)	3 LBS

Quick Adjust WIRE STRAIGHTENER



Durant Wire Straighteners are used for straightening round or flat wire as well as wire with irregular cross sections. Each unit consists of two sets of 5 or 7 "V" grooved rolls set at right angles as illustrated to remove the material curvature on both planes. The rolls on Durant Wire Straighteners can be grooved to the exact diameter of the wire to be straightened or can be "V"-grooved (standard) for handling a wide range of sizes.

Standard Features:

- All rolls can be individually adjusted by means of a thumb screw for precise wire straightening.
- All rolls are mounted on a hardened spindle set in ball bearings for long life.
- Quick opening and closing cam release feature insures a fast set-up and change over from one coil to the next.

Optional Features:

- Roller positioning indicators allow for your operator to easily locate desired roller settings for each job
- All Durant Wire Straighteners may be purchased with one plane only
- GW Wire Servo Roll Feeder
- Manual Hand Crank Drive Rolls on Stand
- Variable Speed Motorized Drive Rolls - Automatic Loop Control
- Variable Speed Motorized Drive Rolls - Hand Pendant Control
- Variable Speed Motorized Drive Rolls - Foot Pedal Control

XWS WIRE STRAIGHTENERS			
Model	Wire Diameter Up To	No. Rolls	Roll Diameter
XWS-007	.062" (1.58 mm)	14	3/4"
XWS-5	.1875" (4.76 mm)	10	1 3/16"
XWS-7	.1875" (4.76 mm)	14	1 3/16"
XWS-5H	.375" (9.53 mm)	10	2 1/4"
XWS-7H	.375" (9.53 mm)	14	2 1/4"

Round/Square Wire Roll Feeders

Features:

- Rugged Compact Feed Body
- Rollers that allow (2) Wire Grooves per Roller
- Mechanical Cam Roll Pressure
- Allen Bradley Electronic Servo Motor and Controls

Options:

- Heavy Duty Adjustable Mounting Bracket
- Special Grooves for Rollers
- Pneumatic Roll Pressure
- Hydraulic Roll Pressure
- Wire Straighteners

Benefits:

- Rugged Mechanical Features that insure long term Problem Free Service
- Machine Design that reduces wire distortion while applying roll pressure
- (3) Year Warranty
- Versatile Feeding Machine for Most Wire Applications

Durant GW Series Electronic Servo Wire Feeders are Compact rugged machines designed specifically for round or shaped wire feeding. When additional gripping force is required, additional feed body modules are utilized to create multiple pinch points on the material. Additional pinch points allow more driving force to be exerted without damaging the wire. Two different wire grooves may be installed on each roll. Roll pressure can be applied with the standard mechanical cam or with optional pneumatic/hydraulic cylinders.

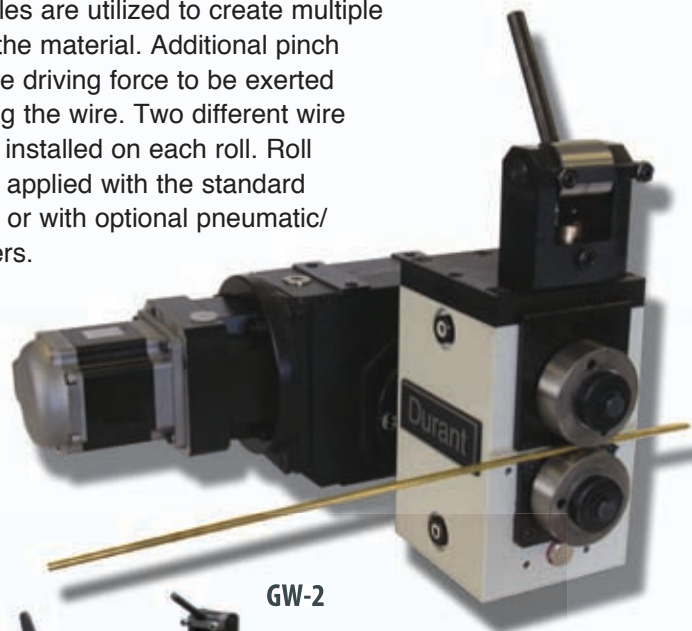

GW-2



XWS-7/GW-1



GW-3



GW WIRE FEEDERS				
MODEL	PULLING CAPACITY	NUMBER DRIVE ROLLS	WIRE DIAMETER	ROLL DIAMETER
GW-1	150 lbs.	2	Up to .375"	2.56"
GW-2	330 lbs.	2	Up to .375"	2.56"
GW-3	660 lbs.	4	Up to .375"	2.56"

***You make \$\$\$ with the Durant Wire Payoff and Uncoilers.
Durant Uncoilers are Productivity Performers! We Guarantee it!***



Flat Material/Wire Measuring Machines

WCMP-1 Wire/ Cable Measuring Machine

When your production application requires measuring wire or cable, look to Durant's complete measuring machine. Precisely and accurately measure your wire or cable to monitor your usage or predetermined requirements. The Durant measuring machine can be ordered with a heavy duty base mounted stand or mounting bracket.

Specification:

- Durant Counter - Model # E5-648-C2421, 120 Volt, (2) Presets, Relay Output
- Encoder Cable - Model #29665300, 10 Foot long or Specify
- Heavy Duty Mounting Stand or Mounting Bracket - Customer Specify
- Durant Encoder - Model #48370060, 60 Pulses per Minute
- Rubber Coated Measuring Wheel - 12" Diameter, #20154301 Kit

Features:

- Heavy Duty Base Mounted Stand or Mounting Bracket
- Non marking material measuring wheel
- Heavy Duty Counter for long term industrial use with (2) presets
- Precise and Accurate Measuring

FMMP-1 Flat Material Measuring Machine

When your production application requires measuring flat material, look to Durant's complete measuring machine. Precisely and accurately measure your materials to monitor your usage or predetermined requirements. The Durant measuring machine can be ordered with a heavy duty base mounted stand or mounting bracket.

Specification:

- Durant Counter - Model # E5-648-C2421, 120 Volt, (2) Presets, Relay Output
- Encoder Cable - Model #29665300, 10 Foot long or Specify
- Heavy Duty Mounting Stand or Mounting Bracket - Customer Specify
- Durant Encoder - Model #48370060, 60 Pulses per Minute
- Urethane Coated Measuring Wheel - 12" Diameter, #20144303 Kit

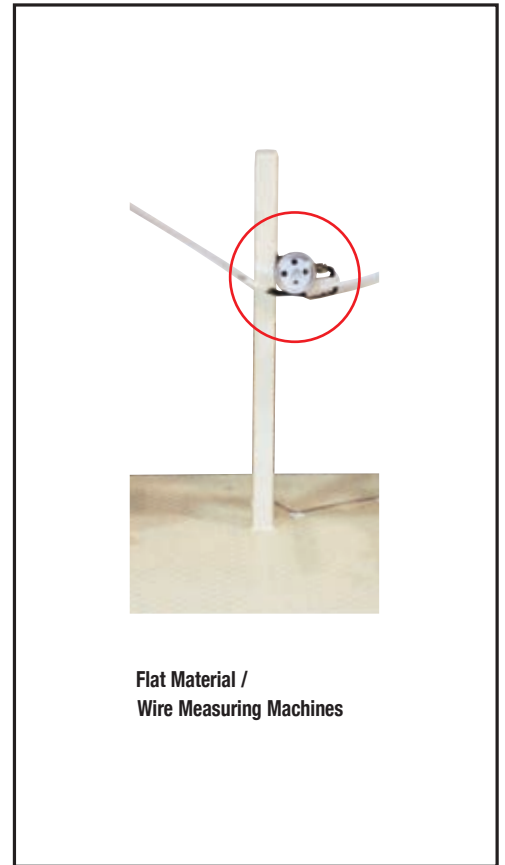

Benefits:

- Precisely and Accurately measure your flat or wire materials
- Quick Set Up
- Monitor material usage
- Monitor production
- (3) Year Warranty

Features:

- Heavy Duty Base Mounted Stand or Mounting Bracket
- Non marking material measuring wheel
- Heavy Duty Counter for long term industrial use with (2) presets
- Precise and Accurate Measuring

WIRE ^{CUT}_{TO} LENGTH MACHINES **ROLL FEEDER CUTTER**

THE COMPACT, ECONOMICAL, EFFICIENT CUT-TO-LENGTH MACHINE

When making an investment in Cut-To-Length Machines, Durant is the solution for your requirements. Durant is a team building the machine suited particularly for your application. Durant can provide you with our standard feed body and electronics package or make necessary modifications at a very reasonable cost. Durant manufactures Servo Roll Feeds that provide power, speed, and precision feed accuracy for all applications.

Durant Tool Company offers 5 models. All feed body parts are precision manufactured with the latest CNC machine technology and have a black oxide machine tool finish. These low maintenance high performance machines incorporate the latest Servo technology.

The Durant Cut-To-Length Machines include our Quick Adjust Wire Straightener, GW Series Electronic Servo Roll Feeder, and powerful pneumatic cutter mounted on a heavy duty machine base.

All Model machines handle a wide range of wire diameters. It gives you our customer, a versatile investment that eliminates the need of using oversized presses or other machines that occupy valuable floor space for simple cut-to-length operations.

The Compact Durant design requires only an air line and power supply. The wire is accurately straightened and fed to the pneumatic cutter knives with guide rollers, keeping the wire straight and perpendicular to the cut.

The electronic control package consists of an operator interface keypad with the industries most user friendly roll feed software on the market today. The keypad contains various system performance data and accumulators.

CUTTER FEATURES:

- Material holding device for optimal cutting accuracy
- Powerful pneumatic or hydraulic cylinder
- Integral guard protection
- Precision holes in blades to fully guide and contain the wire through the cutting process



Selection

Durant manufactures five standard models of high quality competitively priced Cut-To-Length Machines that handle wire to .375" diameter. When cutting materials other than steel, material thickness is considerably greater than stated maximum material thickness, please contact Durant.

Versatility

Durant Servo Feeds are built to handle wires up to .375". If our standard specifications do not meet your requirements, call Durant.

Accuracy

Durant's high quality CNC machined feed body exceeds the manufacturing specifications of all other Servo Feed manufacturers. Cluster gears on top & bottom rolls for zero backlash regardless of material thickness.

Durant's Electronic controls are combined with the most accurate feed body, to give you, our customer the premier Electronic Servo Feed.

Construction

Every model is engineered and machined from the latest CNC Technology and black oxide finished giving our customers the premier Electronic Servo Feed and cutter.

Comparison

Put our machines beside any other comparative unit you have heard about. We won't need to say anything more. You win with Durant! We win with you!

WIRE CUT TO LENGTH MACHINES ROLL FEEDER CUTTER



STANDARD MECHANICAL FEATURES:

- Precision Machined construction.
- Black Oxide finished.
- Matte finish rolls.
- Brushless servo motor.
- Adjustable roller stock guides.
- Heavy duty machine base built to customer specifications.
- Color: Ivory or customer to specify.

STANDARD ELECTRIC CONTROL FEATURES:

- Control enclosure is a rugged 24x20x12" free standing NEMA 12 cabinet. MP cabinet is 20x16x8" deep.
- Operator control: Power On/Off selector switch, Emergency Stop push-pull button, Auto/Manual/Jog to Length selector switch & remote forward / reverse jog station.
- Operator interface keypad and display.
- Electronic Control is wired to JIC and NEC standards.

WCLM Machines			
MODEL	WIRE DIAMETER CAPACITY (mild steel)	CUTTING LENGTH	CUTTING FORCE
WCLM-1	Up to .062" (1.58 mm)	0-999"	1100 lbs.
WCLM-2	Up to .125" (3.25 mm)	0-999"	2200 lbs.
WCLM-3	Up to .1875" (4.76 mm)	0-999"	4400 lbs.
WCLM-4	Up to .240" (6.00 mm)	0-999"	4400 lbs.
WCLM-5	Up to .375" (9.37 mm)	0-999"	11000 lbs.

See Wire Straightener model for detailed Wire Straightener specifications.

STANDARD FEATURES:

- Heavy Duty Machine Base
- GW Wire Servo Roll Feeder
- Pneumatic Cutter

OPTIONAL FEATURES:

- Wire Straightener
- Roll Positioning Indicators for Wire Straightener Rolls
- Wire Decoiler

When your application requires straightening and feeding wire to a precise length; look to Durant. Our space saving, economical wire straighteners/feeders will handle most applications.

Durant Turntables

*Durant manufactures the largest selection of **Non Motorized** and **Variable Speed Motorized Turntables** for every type of requirement.*

*Whatever type of item you want to turn,
Durant has the Rotary Turntable to turn it!*

Durant's Rotary Turntables are utilized for exhibits and displays, factory and industrial automation, packaging industries, and most every type of rotation requirement.

*Our weight capacities range from 50 lbs to 12,000 lbs and turntable diameters to 30'.
Standard turntable rotation speeds are 0-16 rpm or specify.*

All machines have a 3 year warranty utilizing the highest quality components.

The motorized turntables have a variable speed drive controller with foot pedal and reversing features. We insure that the turntable satisfies your specific requirements.



**Table Top
Rotary Turntables
Motorized and Non-Motorized**



**Rotating 115 Volt
Power Outlet In Turntable For Powering
Lighted Displays or Machines**



**High Profile Turntable
Motorized and Non-Motorized**



Pedestal Turntable



**Heavy Duty Custom Rotary
Turntables up to 12,000 lb. Capacity**



**Motorized High Profile Turntable For
Stretch Wrapping**

Exhibit Display Automation Turntables

115 Volt Power Outlet in Turntable Top for Rotating Power
 Ideal for Lighting Rotary Displays and Powering Items on Turntable Top

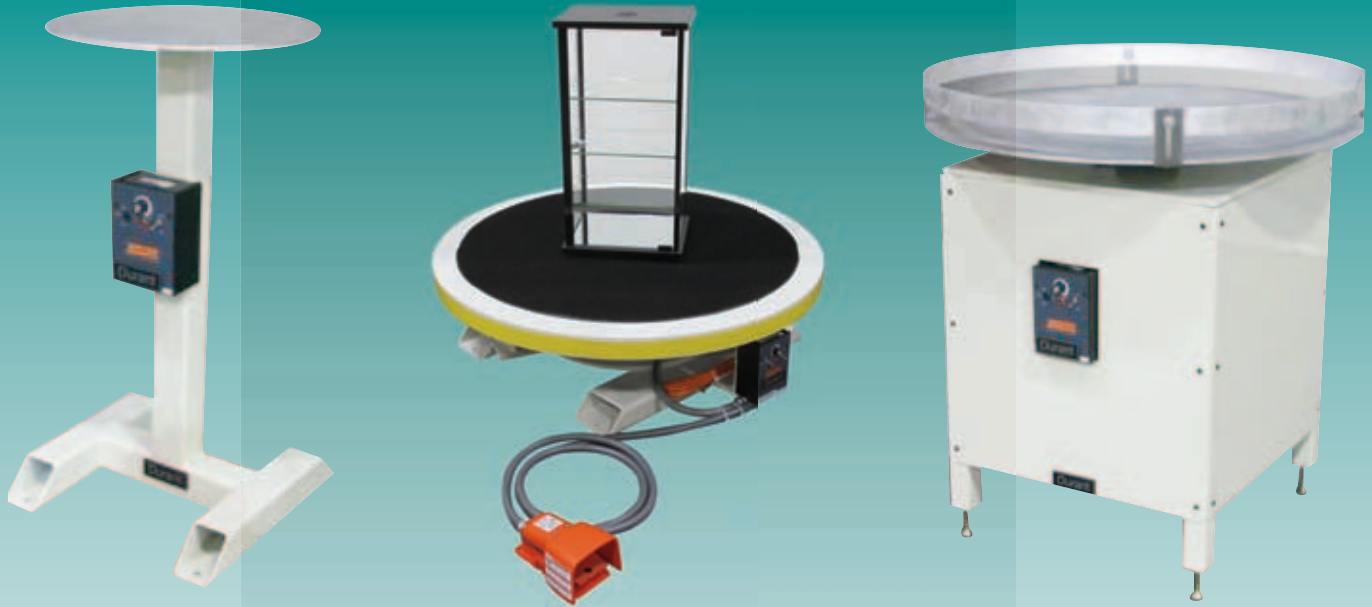

Table Top Rotary Turntables



VARIABLE SPEED MOTORIZED				
Model	Weight Capacity	Height	Turntable Diameter	RPM
LXTP-100-18	100 lbs.(45kg)	9"	18"(457MM)	0-5 or specify
LXTP-250-18	250 lbs.(115kg)	9"	18"(457MM)	0-5 or specify
LXTP-500-18	500 lbs.(228kg)	9"	18"(457MM)	0-5 or specify
LXTP-750-18	750 lbs.(340kg)	9"	18"(457MM)	0-5 or specify
LXTP-100-24	100 lbs.(45kg)	9"	24"(610MM)	0-5 or specify
LXTP-250-24	250 lbs.(115kg)	9"	24"(610MM)	0-5 or specify
LXTP-500-24	500 lbs.(228kg)	9"	24"(610MM)	0-5 or specify
LXTP-750-24	750 lbs.(340kg)	9"	24"(610MM)	0-5 or specify

NON - MOTORIZED MODELS AVAILABLE CALL DURANT!
 SPECIAL TURNTABLE DIAMETERS AVAILABLE
 CALL DURANT!

High Profile Turntables

High Profile Turntables

- 1) Durant Manufactures the largest selection of turntables for:
 - Exhibit Display
 - Factory Automation
 - Packaging/Stretch Wrapping
 - Accumulation and Collecting Items
- 2) Durant offers a standard (3) year warranty on all turntables
- 3) Durant's quality, manufacturing and components are Rated #1
- 4) Durant pricing is always at the most competitive levels

FEATURES:

- USA Manufactured
- Heavy duty, rugged turntable and base construction
- Safe and easy to move with a fork lift
- 3 year warranty
- Models to 12,000 lbs capacity
- Turntable diameters to 30' O.D.
- Speeds 0-16 RPM
- Anti Slip Turntable Cover
- Quiet chain drive. No slippage with belt drives and friction wheels
- Manual Speed Control
- Low voltage foot pedal with an 8' cord
- (2) Heavy duty bearings
- Special sizes to customer specifications
- Custom paint colors to customer specifications

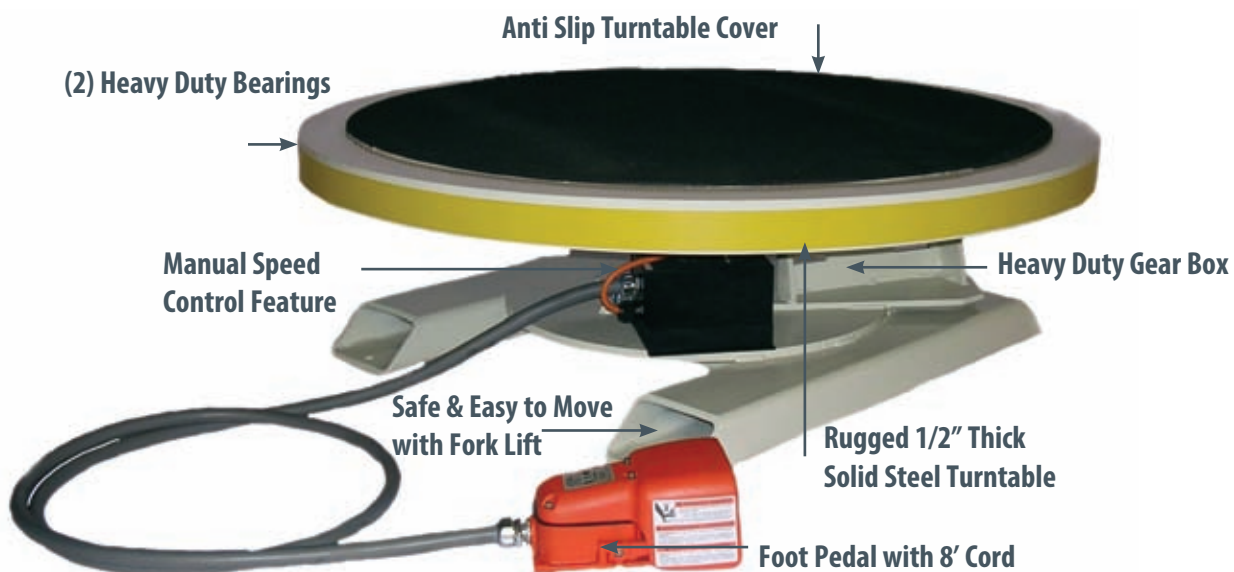

Model XT-4048-M
High Profile Motorized

High Profile Turntables

High Profile Rotary Turntables Non-Motorized		
Model	Weight Capacity	Turntable Diameter
XT-230-U	250 LBS (115 kg)	30" (762 mm)
XT-236-U	250 LBS (115 kg)	36" (915 mm)
XT-248-U	250 LBS (115 kg)	48" (1219 mm)
XT-530-U	500 LBS (228 kg)	30" (762 mm)
XT-536-U	500 LBS (228 kg)	36" (915 mm)
XT-548-U	500 LBS (228 kg)	48" (1219 mm)
XT-1030-U	1000 LBS (455 kg)	30" (762 mm)
XT-1036-U	1000 LBS (455 kg)	36" (915 mm)
XT-1042-U	1000 LBS (455 kg)	42" (1067 mm)
XT-2030-U	2000 LBS (909 kg)	30" (762 mm)
XT-2036-U	2000 LBS (909 kg)	36" (915 mm)
XT-2042-U	2000 LBS (909 kg)	42" (1067 mm)
XT-4036-U	4000 LBS (1818 kg)	36" (915 mm)
XT-4042-U	4000 LBS (1818 kg)	42" (1067 mm)
XT-4048-U	4000 LBS (1818 kg)	48" (1219 mm)
XT-4060-U	4000 LBS (1818 kg)	60" (1524 mm)
XT-5042-U	5000 LBS (2273 kg)	42" (1067 mm)
XT-5048-U	5000 LBS (2273 kg)	48" (1219 mm)
XT-5060-U	5000 LBS (2273 kg)	60" (1524 mm)
XT-5072-U	5000 LBS (2273 kg)	72" (1830 mm)
XT-5084-U	5000 LBS (2273 kg)	84" (2134mm)
XT-5092-U	5000 LBS (2273 kg)	92" (2335 mm)
XT-6048-U	6000 LBS (2721 kg)	48" (1219 mm)
XT-6060-U	6000 LBS (2721 kg)	60" (1524 mm)
XT-6072-U	6000 LBS (2721 kg)	72" (1830 mm)
XT-6084-U	6000 LBS (2721 kg)	84" (2134 mm)
XT-6092-U	6000 LBS (2721 kg)	92" (2335 mm)

High Profile Variable Speed Motorized Rotary Turntables			
Model	Weight Capacity	Turntable Diameter	Motor
XT-230-M	250 LBS (115 kg)	30" (762 mm)	¼ HP 115V
XT-236-M	250 LBS (115 kg)	36" (915 mm)	¼ HP 115V
XT-248-M	250 LBS (115 kg)	48" (1219 mm)	¼ HP 115V
XT-530-M	500 LBS (228 kg)	30" (762 mm)	½ HP 115V
XT-536-M	500 LBS (228 kg)	36" (915 mm)	½ HP 115V
XT-548-M	500 LBS (228 kg)	48" (1219 mm)	½ HP 115V
XT-1030-M	1000 LBS (455 kg)	30" (762 mm)	½ HP 115V
XT-1036-M	1000 LBS (455 kg)	36" (915 mm)	½ HP 115V
XT-1042-M	1000 LBS (455 kg)	42" (1067 mm)	½ HP 115V
XT-2030-M	2000 LBS (909 kg)	30" (762 mm)	¾ HP 115V
XT-2036-M	2000 LBS (909 kg)	36" (915 mm)	¾ HP 115V
XT-2042-M	2000 LBS (909 kg)	42" (1067 mm)	¾ HP 115V
XT-4036-M	4000 LBS (1818 kg)	36" (915 mm)	¾ HP 115V
XT-4042-M	4000 LBS (1818 kg)	42" (1067 mm)	¾ HP 115V
XT-4048-M	4000 LBS (1818 kg)	48" (1219 mm)	¾ HP 115V
XT-4060-M	4000 LBS (1818 kg)	60" (1524 mm)	¾ HP 115V
XT-5042-M	5000 LBS (2273 kg)	42" (1067 mm)	1 HP 115V
XT-5048-M	5000 LBS (2273 kg)	48" (1219 mm)	1 HP 115V
XT-5060-M	5000 LBS (2273 kg)	60" (1524 mm)	1 HP 115V
XT-5072-M	5000 LBS (2273 kg)	72" (1830 mm)	1 HP 115V
XT-5084-M	5000 LBS (2273 kg)	84" (2134mm)	1½ HP 115V
XT-5092-M	5000 LBS (2273 kg)	92" (2335 mm)	1½ HP 115V
XT-6048-M	6000 LBS (2721 kg)	48" (1219 mm)	1 HP 115V
XT-6060-M	6000 LBS (2721 kg)	60" (1524 mm)	1 HP 115V
XT-6072-M	6000 LBS (2721 kg)	72" (1830 mm)	1 HP 115V
XT-6084-M	6000 LBS (2721 kg)	84" (2134 mm)	2 HP 115V
XT-6092-M	6000 LBS (2721 kg)	92" (2335 mm)	2 HP 115V

FEATURES:

- USA Manufactured
- Heavy Duty Rugged Turntables and Base Construction
- Safe and Easy to Move
- Models to 12,000 lbs Capacity
- Special Turntable Diameters to 30'
- Heavy Duty Main Spindle Shaft and Bearings
- Quiet Variable Speed Drive
- Low Voltage Foot Pedal with 8' cord

OPTIONS:

- 115 Volt Power Outlet in Turntable
- Hand Operated Control
- Special Turntable Diameters to 30'
- Special Turntable Height
- Special Weight Capacities to 12,000 lbs
- Indexing Turntable Option
- Zero Speed E/Stop Air Brake System
- Anti Slip Rubber Turntable Cover
- Special Turntable RPM
- Special Paint Color Ivory or Black Standard

BENEFITS:

- Smooth Turntable Rotation
- Heavy Duty Base Construction
- Safe and Easy to Move
- Durant's Quality, Manufacturing and Components are Rated #1
- 3 Year Warranty
- Versatile Machine for many Rotary Turntable Applications
- Durant Pricing is Always at the Most Competitive Levels

**All Stainless Steel
Models with Waterproof
Electronics Available!
Call Durant!**



Stretch Wrap Turntables

FEATURES:

- USA Manufactured
- Heavy duty, rugged turntable and base construction
- Safe and easy to move with a fork lift
- 3 year warranty
- Models to 5,000 lbs capacity
- Turntable diameters to 92" O.D.
- Speeds 0-16 RPM
- Anti Slip Turntable Cover
- 60 pitch quiet chain drive. No slippage with belt drives & friction wheels
- Manual Speed Control
- Low voltage foot pedal with an 8' cord
- (2) Heavy Duty bearings
- Special sizes to customer specifications
- Custom paint colors to customer specifications



Motorized High Profile Turntable For Stretch Wrapping

OPTIONS:

- Hand Operated Control
- Special Turntable Diameters
- Special Turntable Height
- Indexing Turntable Option
- Anti-Slip Rubber Turntable Cover
- Special Turntable RPM
- Special Paint Color Ivory or Black Standard

BENEFITS:

- Smooth Turntable Rotation
- Heavy Duty Base Construction
- Safe and Easy to Move
- Durant's Quality Manufacturing and Components are Rated #1
- (3) Year Warranty
- Versatile Machine for most Stretch Wrapping Applications
- Durant Pricing is Always at the Most Competitive Levels

Model	Weight Capacity	Turntable Diameter	Motor
SW-XT-530-M	500 LBS (227 kg)	30" (762 mm)	½ HP 115V
SW-XT-536-M	500 LBS (227 kg)	36" (915 mm)	½ HP 115V
SW-XT-542-M	500 LBS (227 kg)	42" (1067 mm)	½ HP 115V
SW-XT-1030-M	1000 LBS (455 kg)	30" (762 mm)	½ HP 115V
SW-XT-1036-M	1000 LBS (455 kg)	36" (915 mm)	½ HP 115V
SW-XT-1042-M	1000 LBS (455 kg)	42" (1067 mm)	½ HP 115V
SW-XT-2030-M	2000 LBS (909 kg)	30" (762 mm)	¾ HP 115V
SW-XT-2036-M	2000 LBS (909 kg)	36" (915 mm)	¾ HP 115V
SW-XT-2042-M	2000 LBS (909 kg)	42" (1067 mm)	¾ HP 115V
SW-XT-4036-M	4000 LBS (1818 kg)	36" (915 mm)	¾ HP 115V
SW-XT-4042-M	4000 LBS (1818 kg)	42" (1067 mm)	¾ HP 115V
SW-XT-4048-M	4000 LBS (1818 kg)	48" (1219 mm)	¾ HP 115V
SW-XT-4060-M	4000 LBS (1818 kg)	60" (1524 mm)	¾ HP 115V
SW-XT-5042-M	5000 LBS (2273 kg)	42" (1067 mm)	1 HP 115V
SW-XT-5048-M	5000 LBS (2273 kg)	48" (1219 mm)	1 HP 115V
SW-XT-5060-M	5000 LBS (2273 kg)	60" (1524 mm)	1 HP 115V
SW-XT-5072-M	5000 LBS (2273 kg)	72" (1830 mm)	1 HP 115V

**All Stainless Steel
Models with Waterproof
Electronics Available!
Call Durant!**



Pedestal/Cabinet Turntables

Pedestal Turntables									
Model	Base	Turntable and Pedestal	Turntable Diameter	Leveling Feet 2" ±	Turntable RPM	Motor	Turntable Rim	Turntable Height	Reversible Variable Speed Control with Foot Pedal
SP-1000-PT	Pedestal	Painted Steel	12"-30"	4	0-16 RPM	1/8 HP 115V	Cage Type	34"	Standard

Cabinet Turntables									
Model	Base	Turntable and Cabinet	Turntable Diameter	Leveling Feet 2" ±	Turntable RPM	Motor	Turntable Rim	Turntable Height	Reversible Variable Speed Control with Foot Pedal
SP-2030-CT	Cabinet	Painted Steel	30"	4	0-16 RPM	1/2 HP 115V	Cage Type	34"	Standard
SP-2036-CT	Cabinet	Painted Steel	36"	4	0-16 RPM	1/2 HP 115V	Cage Type	34"	Standard
SP-2042-CT	Cabinet	Painted Steel	42"	4	0-16 RPM	1/2 HP 115V	Cage Type	34"	Standard
SP-2048-CT	Cabinet	Painted Steel	48"	4	0-16 RPM	3/4 HP 115V	Cage Type	34"	Standard
SP-2060-CT	Cabinet	Painted Steel	60"	4	0-16 RPM	3/4 HP 115V	Cage Type	34"	Standard

Durant manufactures 6 Standard models of Pedestal and Cabinet mounted Variable Speed Motorized Turntables. Standard Turntable diameters are from 12" diameter to 60" diameter. Special Turntable diameters are available to customer specifications.

All models have a standard height of 34" from the turntable surface to the base. 4 adjustable leveling feet, with a ± 2" adjustment, are standard equipment with each turntable. Other heights are available. Customer to specify at no additional cost.

Durant Rotary Turntables are supported by a center drive shaft and hub. A variable speed drive with foot pedal and reversible switch insures that the turntable satisfies your specific requirements.

FEATURES:

- USA Manufactured
- Heavy Duty Rugged Turntables and Base Construction
- Safe and Easy to Move
- Models from 12" diameter to 60" diameter Turntables
- Rugged Main Spindle Shaft and Bearings
- ±2" Adjustable Height with Leveling Feet
- Quiet Variable Speed Drive
- Low Voltage Foot Pedal with 8' Cord
- Low Voltage Hand Control

OPTIONS:

- Hand Operated Control
- Special Turntable Diameters
- Special Turntable Height
- Indexing Turntable Option
- Servo Drive Controller Option
- Solid Turntable Rim (Up or Down Specify)
- Special Paint Color

BENEFITS:

- Smooth Turntable Rotation
- Rugged Base and Cabinet Construction
- Highest Quality Components
- 3 Year Warranty
- Versatile Machine for many Rotary Turntable Applications



Pedestal Turntable



Cabinet Turntable with Turntable Rim

Durant Counters

Electric Counters

Electric Counters

No. of Figures	Voltage	Reset	Mounting	Model
7	24 Vdc	Knob	Panel	7-Y-1-RMF-PM-24D
6	115 Vac	Knob	Base	6-Y-1-RMF-115A
7	115 Vac	Non-reset	Base	7-Y-13-RMF-115A
6	115 Vac	Knob	Panel	6-Y-1-RMF-PM-115A
7	115 Vac	Non-reset	Panel	7-Y-13-RMF-PM-115A
6	115 Vac	Non-reset	Base	6-Y-13-RMF-115A
6	115 Vac	Knob	Panel	6-Y-1-RMF-PM-115A
6	115 Vac	Keylock reset	Panel	6-Y-12-RMF-PM-115A
6	230 Vac	Keylock reset	Panel	6-Y-12-RMF-PM-230A
7	115 Vac	Keylock reset	Panel	7-Y-12-RMF-PM-115A
6	24 Vac	Keylock reset	Panel	6-Y-12-RMF-PM-24A
6	24 Vdc	Keylock reset	Panel	6-Y-12-RMF-PM-24D
7	24 Vdc	Keylock reset	Panel	7-Y-12-RMF-PM-24D
7	230 Vac	Keylock reset	Panel	7-Y-12-RMF-PM-230A
6	24 Vac	Knob	Panel	6-Y-1-RMF-PM-24A
6	240 Vac	Knob	Panel	6-Y-1-RMF-PM-240A
6	115 Vac	Knob	Panel	6-Y-1-RMF-PM-115A
6	115 Vac	Non-reset	Panel	6-Y-13-RMF-PM-115A
7	24 Vdc	Non-reset	Panel	7-Y-13-RMF-PM-24D

“RMF” Series Electromechanical Counters

Model RMF Series electric counters are designed to give accurate counts through a wide range of speeds up to 1000cpm. It features a strong, silent, fast operating DC electromagnetic drive with a compact, dependable built-in higher capacity rectifier for AC operation. The counter has a minimum of moving parts that never need lubrication under normal operating conditions. Compact and rigid, it continues to operate dependably even when subject to several shock and vibrations. Entirely enclosed to prevent damage from moisture and dust. Available in 6 or 7 figures.

Selection

To determine a model number from the product selection for model RMF Series Electronic Counters consider:

- Number of Figures
- Type of Reset
- Voltage
- Type of Mounting

Benefits

- Heavy Duty Counter and Accessories for long term trouble free operation and counting
- Monitor Production
- Precisely and Accurately measures your raw material or finished parts
- Quick Set-Up
- (3) Year Warranty



“RMF” Series Electromechanical Counters

“ME” Series Miniature Electric Counters

Small in size and price, but large in design versatility and model variety is the ME Series of miniature electric counters. Models in most popular AC or DC voltages operate on as little as 3 watts, with the non-reset models measuring only 1x1.593x2in (25.4x40.5x55.5mm) and weighing just three ounces (85grams). Available in 4, 6 or 7 figures, the counters feature stainless steel self-lubricating shafts, nylatron pinions and a synchronous electromagnetic drive to assure accurate, reliable long life operation. Designed for mounting flexibility and aesthetic attractiveness, the miniature electric counters are available with three types of mounting and a glare retarding finish Delrin, with crisp easy-to-read numerals set close to a tamper-proof sealed figure window

Selection

When ordering ME Series Miniature Electric Counters. Specify catalog numbers according to the features selected

Benefits

- Heavy Duty Counter and Accessories for long term trouble free operation and counting
- Monitor Production
- Precisely and Accurately measures your raw material or finished parts
- Quick Set-Up
- (3) Year Warranty



ME Series Miniature Electric Counters

No. of Figures	Voltage	Reset	Mounting	Model
4	12 Vdc	Pushbutton	Bottom	4-Y-41312-401-MEQ
4	24 Vdc	Pushbutton	Bottom	4-Y-41312-402-MEQ
4	120 Vac	Pushbutton	Bottom	4-Y-41312-406-MEQ
4	24 Vdc	Pushbutton	Base	4-Y-41313-402-MEQ
4	120 Vac	Pushbutton	Base	4-Y-41313-406-MEQ
4	240 Vac	Pushbutton	Base	4-Y-41313-407-MEQ
4	12 Vdc	Pushbutton	Panel	4-Y-41314-401-MEQ
4	24 Vdc	Pushbutton	Panel	4-Y-41314-402-MEQ
4	120 Vdc	Pushbutton	Panel	4-Y-41314-406-MEQ
4	240 Vdc	Pushbutton	Panel	4-Y-41314-407-MEQ

“ME” Series Miniature Electric Counters



Durant Counters

Stroke Counters

“X” Series Stroke Counters/Pushbutton Desk Tallies

Model X Series is a dustproof and rustproof series of counters for light and medium-duty work. They are sound and durable, requiring a minimum of driving effort, and have been especially designed for incorporation as integral parts of a variety of machines and equipment.

Selection

To determine a model number from the product selection table for Model X Series Stroke Counters and Pushbutton Desk Tallies consider

- Number of Figures
- Drive

Benefits

- Heavy Duty Counter and Accessories for long term trouble free operation and counting
- Monitor Production
- Precisely and Accurately measures your raw material or finished parts
- Quick Set-Up
- (3) Year Warranty



“X” Series Stroke Counters

Stroke Counters: Light Duty

No. of Figures	Drive	Reset	Mounting	Model
5	LH Lever	Knob	Base	5-X-1-1-L
4	RH Lever	Knob	Base	4-X-1-1-R
5	RH Lever	Knob	Base	5-X-1-1-R
5	LH Lever	Knob	Panel	5-X-1-1-L-REV
5	RH Lever	Knob	Panel	5-X-1-1-R-REV
4	Push bar	Knob	Base	4-X-2

“D” Series Stroke Counters

Model D Series are medium duty stroke counters available with 4, 5 or 6 figures that have been designed for general service on small production machines. Although compact D models are sturdily constructed and thoroughly tested for accuracy and efficient operation.

Description	Specification
Figures	4, 5 and 6
Speed	400 cpm
Shaft	0.25 in (6.4 mm) diameter stainless steel, rustproof
Drive	Nylon ratchet and Delrin drive plate. Right-hand drive standard; left-hand drive available
Bearings	Oil-less, maintenance free
Figure size	1/4 in (6.4 mm) high, black-on-white background
Reset	Wing nut
Finish	Black frame and cover
Operating lever	Adjustable to any position. Furnished complete with pull string

Stroke Counters: Medium Duty

No. of Figures	Voltage	Reset	Mounting	Model
4	RH Lever	Wing nut	Base	4-D-1-1-R
5	RH Lever	Wing nut	Base	5-D-1-1-R
6	RH Lever	Wing nut	Base	6-D-1-1-R
4	LH Lever	Wing nut	Base	4-D-1-1-L
5	LH Lever	Wing nut	Base	5-D-1-1-L



“D” Series Stroke Counters

Stroke Counters: Heavy Duty

No. of Figures	Drive	Reset	Mounting	Model
5	RH Lever	Wing nut	Base	5-H-1-1-R
5	LH Lever	Wing nut	Base	5-H-1-1-L
5	RH Lever	Wing nut	Base	5-H-1-1-R-REV
5	LH Lever	Wing nut	Base	5-H-1-1-L-REV
5	RH Lever	Wing nut	Base	5-H-1-1-R-RP
5	LH Lever	Wing nut	Base	5-H-1-1-L-RP
5	RH Lever	Lock reset	Base	5-H-1-2-R
5	LH Lever	Lock reset	Base	5-H-1-2-L
5	RH Lever	Lock reset	Base	5-H-1-2-R-RP
5	RH Lever	Wing nut	Rear	5-H-1-4-R
5	RH trip arm	Wing nut	Base	5-H-5-A
5	RH trip arm	Wing nut	Base	5-H-5-B
5	LH trip arm	Wing nut	Base	5-H-5-C
5	LH trip arm	Wing nut	Base	5-H-5-D
5	RH trip arm	Lock reset	Base	5-H-6-A
5	RH trip arm	Lock reset	Base	5-H-6-B
5	LH trip arm	Lock reset	Base	5-H-6-C
5	LH trip arm	Lock reset	Base	5-H-6-D

“H” Series Stroke Counters

Model H Series heavy duty counters are designed for hard usage and long trouble free service. They are high speed, streamlined counters constructed of the highest quality materials and drive shaft moves in oil-less bearings. All shafts are stainless steel.

The drive action is designed to overstroke so counter does not bottom increasing life and permitting easier installation. The sturdy cover is stamped steel, locked into position on a heavy die-cast base of a special alloy. A heavy steel mounting plate is adjustable for either bottom or back mounting. Model H has earned the reputation of being the work horse of industrial counters. Wing nut or tamper-proof reset lock which requires a key to reset the counter, guarding against unauthorized resetting or tampering.

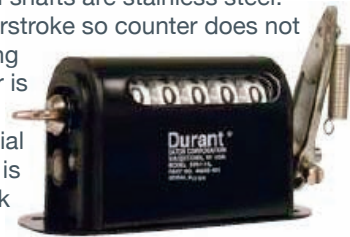

“H” Series Stroke Counters



Durant Counters

Measuring / Revolution Counters

“D” -7 Series Measuring/Revolution Counters

Model D-7 Series spur gear end drive units are compact counters that meet a variety of needs. Accurate, dependable and moderately priced, they are especially recommended for braiding machines. low-speed coil winders, wire measuring equipment and all medium duty revolution applications.

Selection

To determine a model number from the product selection table for model D-7 Series Revolution Counters consider

- Number of Figures
- Shaft Rotation Direction
- Shaft Drive
- Reset or Non-Reset

Benefits

- Heavy Duty Counter and Accessories for long term trouble free operation and counting
- Monitor Production
- Precisely and Accurately measures your raw material or finished parts
- Quick Set-Up
- (3) Year Warranty



“D-7” Series Revolution Counter

No. of Figures	Drive	Rotation	Reset	Mounting	Model
5	LH	Clockwise	Wing nut	Base	5-D-7-1-L-CL
5	LH	Anti-clockwise	Wing nut	Base	5-D-7-1-L-AC
5	RH	Clockwise	Wing nut	Base	5-D-7-1-R-CL
5	RH	Anti-clockwise	Wing nut	Base	5-D-7-1-R-AC
5	LH	Anti-clockwise	None	Base	5-D-7-3-L-AC
5	RH	Clockwise	None	Base	5-D-7-3-R-CL

“H” Series Measuring/Revolution Counters

Model H Series are heavy-duty, end drive revolution counters designed for industrial use, suitable for speeds up to 800cpm. They are available with either right or left hand drive and with wing nut reset.



H Series Revolution Counter

No. of Figures	Drive	Rotation	Reset	Mounting	Ratio	Model
5	LH	Clockwise	Wing nut	Base	1.1	5-H-7-1-L-CL
5	LH	Anti-clockwise	Wing nut	Base	1.1	5-H-7-1-L-AC
5	RH	Clockwise	Wing nut	Base	1.1	5-H-7-1-R-CL
5	RH	Anti-clockwise	Wing nut	Base	1.1	5-H-7-1-R-AC
5	LH	Clockwise	Wing nut	Base	3.2	5-H-8-1-L-CL
5	LH	Anti-clockwise	Wing nut	Base	3.2	5-H-8-1-L-AC
5	RH	Clockwise	Wing nut	Base	3.2	5-H-8-1-R-CL
5	RH	Anti-clockwise	Wing nut	Base	3.2	5-H-8-1-R-AC
5	LH	Clockwise	Wing nut	Base	1.2	5-H-9-1-L-CL
5	LH	Anti-clockwise	Wing nut	Base	1.2	5-H-9-1-L-AC
5	RH	Clockwise	Wing nut	Base	1.2	5-H-9-1-R-CL
5	RH	Anti-clockwise	Wing nut	Base	1.2	5-H-9-1-R-AC
5	LH	Clockwise	Wing nut	Base	1.2	5-H-9-0-1-L-CL
5	RH	Clockwise	Wing nut	Base	1.2	5-H-9-0-1-R-CL
5	RH	Anit-clockwise	Wing nut	Base	1.2	5-H-9-0-1-R-AC

Top View-LH Drive



Clockwise Shaft Rotation



Anti-Clockwise Shaft Rotation

Top View-RH Drive



Clockwise Shaft Rotation



Anti-Clockwise Shaft Rotation

Top View-RH and LH

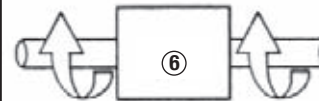

Clockwise Shaft Rotation

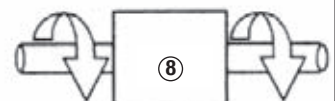

Anti-Clockwise Shaft Rotation

Measuring Wheels

Measuring wheel mounts to Durant Encoders and Rotary contactor to allow for accurate measurements.



Measuring Wheels

Description	Model
5/16 in bore, urethane rim	20144300KIT
3/8 in bore, urethane rim	20144303KIT
5/16 in bore, rubber rim	20154300KIT
3/8 in bore, rubber rim	20154301KIT
5/16 in bore, knurled rim	20156300KIT
3/8 in bore, knurled rim	20156301

Mounting Bracket for “D” Series

Counters & Rotary Contactors

Mounting Bracket for Durant-D-Series Counters and Rotary Contactors

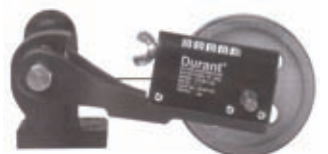

Mounting Bracket

Durant Counters

Ambassador Series



Ambassador Series (Totalizers)

Durant's Ambassador Series is our most noise-immune totalizer available. Various counting modes can be set by the user.

Description	Model
10-15 Vdc LCD	57600400
115 Vac LCD	57601400
230 Vac LCD	57602400

Benefits:

- Heavy Duty Counter and Accessories for long term trouble free operation and counting
- Monitor Production
- Precisely and Accurately measures your raw material or finished parts
- Quick Set-up
- (3) Year Warranty

Features:

- AC/DC powered two-line LCD display
- 1/Tau Ratemeter
- Four user Configurable Controls Inputs
- RS-485 Series Communications
- Eight-Digit Totalizer
- Totalizer and Ratemeter Scaling
- Two Solid State Outputs

LCD Totalizers

Features:

- Low Price and High Efficiency
- Various counting models like up/down differential available
- IP65
- Locking of the reset key
- All version of positive or negative counting edge
- Large eight-digit LCD display, height of the figures 0.31 in (8mm)
- High voltage input for 10-260 Vac/Vdc voltage pulses
- Screw terminals, RM 5mm
- Operating temperature 14 to 140F (-10 to 60C)
- Filter function for bounce-free counting with mechanical contacts



LCD Totalizers

Description	Model
Eight-Digit LCD Totalizer, Battery Power	
4—30 Vdc powered, NPN/PNP 0.94x1.89in (24x48mm)	E5-024-C0400
10—120V input AC/DC powered, NPN only 0.94x1.89in (24x48mm)	E5-024-C0408
Count up/down 4—30 Vdc powered, NPN only 0.94x1.89in (24x48mm)	E5-024-C0410

Description	Specification
Power Supply	Non-replaceable lithium battery (lifetime approximately eight years at 68°F (20°C))
Display	LCD, eight-digits
Figure Size	0.31 in (8 mm) high
Mode	Adding or subtracting (selectable), counting direction, differential counting or phase discriminator single or dual evaluation (selectable)
Display Range	-9999999 to 99999999, with overflow display
Reset	Manual and electrical
Interference emissions	EN 55011 Class B, EN 61 000-6-2, EN 61010 Section 1 (only AC versions)
Housing	Dark gray RAL 7021
Operating temperature	14° to 131°F (-10° to 55°C)
Ambient temperature	14° to 140°F (-10° to 60°C)
Storage temperature	-4° to 158°F (-20° to 70°C)
Protection	IP65 (from front)
Weight	Approx. 1.76 oz (50g)

Description	Specification
Power Input	
AC operation	115 Vac (±15%)std., 50 to 60 Hz, 7W 230 Vac (±15%)opt., 50 to 60 Hz, 7W
DC operation	10-15 Vdc opt., 300 mA maximum
DC Power output	12 Vdc (±25%), 100 mA maximum (includes all line and load variations)
Environmental	
Operating temperature	32° to 131°F (0° to 55°C)
Storage temperature	-4° to 158°F (-20° to 70°C)
Operating humidity	85% relative, non-condensing
Rating	NEMA 4 When mounted with gasket provided
Totalizer	
Type	Bi-directional
Digits	Eight
Scaler Range	0.00001 to 9.99999
Decimal point	Five positions, programmable
Average time	0.1 to 99.9 seconds, programmable

Ambassador Series Ratemeter

Durant's Ambassador Series provides up to four presets in one of the most noise-immune packages available.

Features:

- AC/DC powered two-line LCD display
- Two-line, five-digit high visibility 0.3in (7.5mm)
- Characters backlit display
- One or Two Rate Inputs
- Two Rate Alarms
- Dual rate unit calculations A/B, A-B or draw
- Programmable average and zero times
- Programmable decimal point
- 12Vdc, 100mA max output power
- Removable screw terminals
- RS-485 Communications
- NEMA 4 Front Panel

No. of Figures	Drive
Power Input	
Model 57150-40X	10 to 15 Vdc, 300 mA maximum
Model 57151-40X	115 Vac(±15%)50-60Hz, 7W
Model 57152-40X	230 Vac(±15%)50-60Hz, 7W
DC Power Output	(AC Models Only)
Output	12 Vdc(±25%), 100 mA maximum (includes all line and load variations)
Environment	
Operating temperature	32° to 131°F (0° to 55°C)
Storage temperature	-4° to 158°F (-20° to 70°C)
Operating humidity	85% relative, non-condensing
NEMA 4 rating	When mounted with gasket provided
Ratemeter	
Type	1/Tau
Digits	Five with overrange indication
Scaler Range	0.00001 to 99999
Decimal point	Five positions, programmable
Average time	0.1 to 99.9 seconds, programmable
Zero time	0.1 to 99.9 seconds, programmable
Accuracy	±0.015% of reading

Durant Counters

President Series

Profitable high speed industrial production depends on the accuracy of the way you monitor and control it. Why settle for less than the Ambassador and Presidential Series from Durant. We were the first on the market with these high tech digital controls, and we have constantly improved them ever since. Right now, for example, you can order these no-compromise Durant Counters with the options you need to do just about anything you want:

- Simple Production Counting
- Length measurement
- Cut-to-Length Operations
- Batching, Packaging, or Roll Forming
- Blending or Dispensing
- Motor Speed Monitor Control
- Printing
- Parts Counting or Coil Winding
- Wide Range of Other Industrial Applications



President Series Count Control

No. of Figures	Features	Batch Counter	Rate	Scaler	Cropcut	Main Counter	Presets	Digits	Model
120 Vac, no Communications	—	—	✓	—	—	1	1	5	57820400
Single Preset	—	—	—	—	—	1	1	5	58821400
Single Preset w/rate	—	—	✓	✓	—	1	1	5	58825400
Dual Preset	—	—	—	✓	—	1	2	5	58831400
Dual Preset w/Batch	—	✓	—	✓	✓	1	2	6	58841400
Dual Preset w/totalizer or batch counter	1	1	—	✓	✓	1	2	6	58851400
Three presets /floating pre-warn	—	—	—	✓	—	1	3	6	58861400
Main counter, batch & totalizer presets	2	2	✓	✓	—	3	1 ea.	6	58827400
Two independent count registers	3	3	✓	✓	—	3	1 ea.	6	58827410
High-speed count control—30 kHz max.	—	✓	✓	✓	—	1	2	6	58827400
President position controller									58868400

The President Series leads the way with features like these:

- Color-coded Keyboard Panel for dependable and simple selection, indication, control and programmability.
- Bright .56" Seven-Segment LED Display for easy-to-read count and preset values.
- Sealed Front Panel to NEMA 4 Specifications for complete environmental protection.
- Two-way 20 MA Loop Communications 1200 baud serial communications.
- Ideal Power Input 115/230 VAC and 11-28 VDC for versatility in application.
- System Matched Auxiliary Power for instant hook-up of flow cost DC input devices at correct voltage and current design.
- Full Line of Transducers and Sensors for one-source systems design.
- Relay and Transistor Outputs to meet every control requirement.
- Non-Volatile Memory for no loss of memory – no batteries required.

Rotary Contactor

Designed for use on fillers, crowners, washers, conveyors and other bottling machinery. Counts one-half pints, pints and quarts – either round or square type. Adjustable tension screw prevents spinning assures peek accuracy. Gear box is changeable to any of four positions, giving great flexibility of installation.

Rotary Contactor

Model	Description
ES9513RS	12:1 Ratio Reed Switch Output
ES9513RS	10:1 Ratio Reed Switch Output
ES9513RS	1:1 Ratio Reed Switch Output
ES9513RS	1:3 Ratio Reed Switch Output
ES9513RS	1:3.28 Ratio Reed Switch Output
ES9513RS	1:10 Ratio Reed Switch Output
ES9513	1:10 Ratio Leaf Switch Output
ES9513	1:1 Ratio Leaf Switch Output
ES9513	1:3 Ratio Leaf Switch Output

and quarts – either round or square type. Adjustable tension screw prevents spinning assures peek accuracy. Gear box is changeable to any of four positions, giving great flexibility of installation.

Benefits:

- Heavy Duty Counter and Accessories for long term trouble free operation and counting
- Monitor Production
- Precisely and Accurately measures your raw material or finished parts
- Quick Set-up
- (3) Year Warranty

Features:

- Five or Six digit LED Display, 056 in (14mm)
- 15 Vdc at 100 mA Output Power
- 20 mA Current Loop Communications
- Tactile Keypad NEMA 4 Front Panel
- 1,2 or 3 Presets
- Real Panel Screw Terminals
- 2 Form C Relays

Cube Shaft Encoders



Provides accurate pulse outputs for use with PLCs and counter

Cube Shaft Encoders

Selection

Cube Shaft Encoders

Description	Normally Stocked Item	Model
Single Channel		
60 pulses per revolution	—	38150060
100 pulses per revolution	Yes	38150100
120 pulses per revolution	—	38150120
600 pulses per revolution	Yes	38150600
Quadrature		
60 pulses per revolution	—	38151060
100 pulses per revolution	Yes	38151100
120 pulses per revolution	—	38151120
600 pulses per revolution	Yes	38151600

Features:

- 5-28 Vdc Input Power
- NPN Transistor Output, 250 mA Sinking Capacity
- Single Channel and Quadrature Models
- 3/8 in (9.5mm) Double Ended Shaft
- Tapped Holes for Face or Base Mounting
- 80 mA Current Draw
- Square Wave Output, (50-50 Duty Cycle)
- Up to 600 Pulses per Revolution
- ABEC Three Double Sealed Ball Bearings
- Military Style Connector

Accessory

Mounting Bracket for Encoders

Description	Normally Stocked Item	Model
Mounting Bracket	—	40460402



4 Easy Ways to Order

Quality Products • Competitive Pricing • Reliable Delivery



1 PHONE

Toll-Free 1-800-D-Durant
(1-800-338-7268) or
1-401-781-7800

2 FAX

By Calling 1-401-738-2586
24 Hours a Day

3 MAIL

200 Circuit Drive
North Kingstown, RI 02852

4 E-MAIL

sales@durantco.com

All Components manufactured by Durant Tool Company are warranted for three years against defects in material or workmanship, given normal and intended use. Durant will repair or replace all equipment at its discretion. Durant reserves the right to make changes in all specifications and components.

Limited Warranty: All electrical and electronic components must be inspected to determine whether they will be warranted prior to replacement being sent. Motors, reducers, controls and items manufactured by companies other than Durant are warranted by their manufacturer and will be repaired or replaced at their discretion. Durant Tool Company does not assume responsibility for those items.

We make no warranty as to the adaptability of our equipment to the customer's application. This is determined by the customer and the dealer or his representatives.

This warranty supersedes all previous warranties made by Durant either expressed or implied.

Please follow these instructions for the fastest and most accurate processing of your order.

- Order by model number. Give a brief description of the item and specific quantities desired.
- Give your purchase order number, name, phone number, and any special instructions.
- Our friendly, qualified telephone personnel are available for fast, convenient, dependable service or if you have any questions about your order. Just call **TOLL FREE 1-800-D-DURANT**

PROMPT QUOTATIONS

Write, phone or FAX us for a quotation on any item. Even items not currently listed in our catalog. You will receive a prompt and detailed response on both price and delivery.

CUSTOMER SERVICE

Durant account managers, data entry staff, and customer service specialists are a team that focus on your needs. We're not satisfied until you are!

SPECIAL SERVICES

If you have special shipping or billing requests, please let us know. We have the ability to record special instructions; and make sure they are followed - every time. Let our flexibility work for you.

PRICING

We attempt to maintain the prices quoted as long as possible and expect to honor them. All prices are subject to change without notice due to printing and production error or extraordinary market conditions. The price charged will be that which is in effect at the time of Durant's acceptance of your order.

MINIMUM ORDERS - \$100.00 Net

RETURNS AND EXCHANGES

When you must return merchandise to us, please follow these simple procedures:

1. Please do not return merchandise without notifying us first and receiving our authorization.
2. Pack merchandise in a strong container.
3. Be sure to include a copy of the invoice.
4. Ship prepaid only.
5. Please allow adequate time for us to receive the package, inspect its contents and make the appropriate adjustment. We will handle your return as quickly as possible.

NOTE: We reserve the right to charge a restocking fee of 20% - 90% on all orders returned.

All parts and/or electronic items are not subject to return. There are no exceptions.

CANCELLATION

If a cancellation is received by Durant, after purchase number is issued, Durant reserves the right to charge a 20% - 90% cancellation fee. This fee is charged on all special machines and specific standard machines.

DURANT TOOL COMPANY is on the internet.

www.durantco.com

Tips & Answers to the Most Asked Questions!

Safeguarding of Machines

Never operate, install or maintain machines without understanding the complete and safe operation of that specific equipment.

It is the employer's responsibility to provide proper safety devices and equipment to safeguard the operator from harm and to safeguard these machines

at all times in order to meet all current state and federal government safety codes and standards.

All machines must be securely attached to the floor.

Damaged / Lost Items

The carrier who delivers the merchandise is responsible for loss or damage, whether it is the U.S. Postal Services,

United Parcel Service, or truck, since all products are sold F.O.B. our warehouse.

Misprint

Although we have made every effort to ensure the accuracy of information in this catalog, we cannot always control and are not responsible for printing errors and / or omissions.

Machine Color

Color of machines may not be the same as illustrated in this catalog, but can be specified.

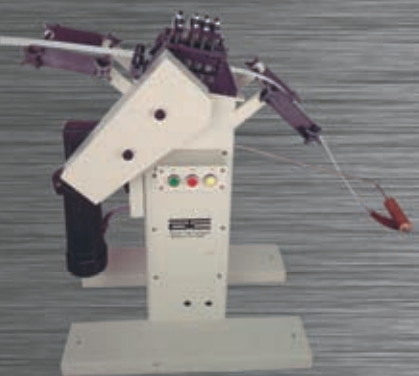
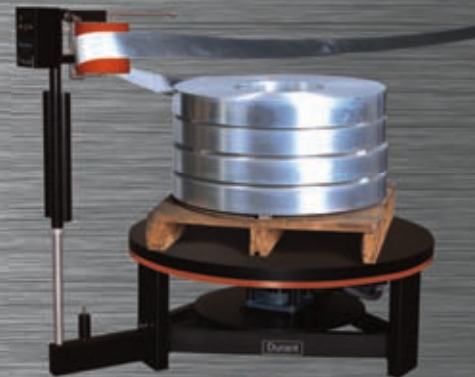
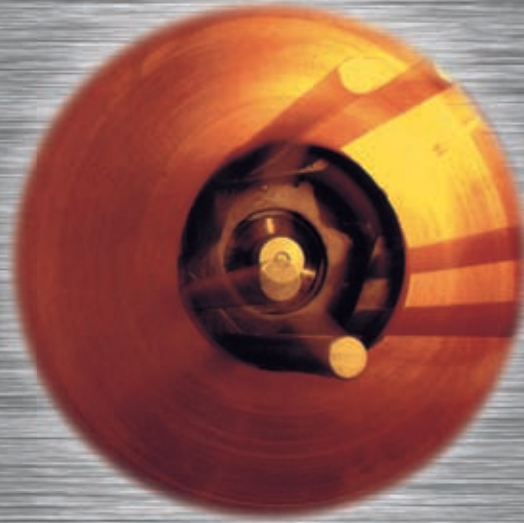
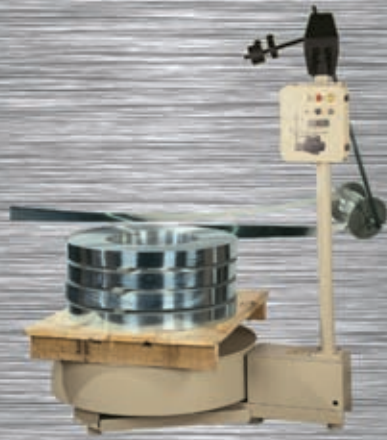

Durant Tool Company
 200 Circuit Drive
 North Kingstown, RI 02852 USA
 (401) 781-7800
 (800) 338-7268
 Fax: (401) 738-2586

www.durantco.com

